

Technical Information

TI 04L55B01-01EN

Data Acquisition System Introduction to the Various Features of the GM

SMARTDAC+[™]



Blank Page

Data Acquisition System

Introduction to the Various Features of the GM

TI 04L55B01-01EN

CONTENTS

Using This Document	i
1. What Is SMARTDAC+ GM?.....	1-1
1.1 Functions That Ensure Reliable Measurements.....	1-2
1.1.1 Rich I/O Interface.....	1-2
1.1.2 Actual Values Underlying Accurate Measurements.....	1-3
1.1.3 Fail-safe Saving of Recording Data	1-4
1.1.4 Easy Access from Web Browser	1-5
1.1.5 Offline Configuration and Monitoring	1-6
1.2 A Full System Configuration Example.....	1-7
1.3 GM Application Examples	1-8
2. Scalable Data Acquisition System	2-1
2.1 Component Devices.....	2-1
2.3 Unit Types and Configurations	2-5
3. Functions.....	3-1
3.1 Basic Functions.....	3-1
3.1.1 Measurement	3-1
3.1.2 Recording	3-7
3.1.3 Output.....	3-11
3.1.4 Storage	3-12
3.1.5 Display (Web browser).....	3-13
3.2 Various Functions	3-15
3.2.1 Alarm Function	3-15
3.2.2 Event Action Function.....	3-18
3.2.3 Control Event Action Function	3-21
3.2.4 Batch Function.....	3-23
3.2.5 Math Function (/MT option)	3-24
3.2.6 Logic Math Function	3-26
3.2.7 Report Function (/MT option)	3-26
3.2.8 Report Template Function	3-27
3.2.9 Security Function.....	3-28
3.2.10 Fail, Status Output.....	3-30
3.2.11 Timer and Internal Switch Functions	3-31
3.2.12 Log Scale Function (/LG option).....	3-32
3.3 Communication and Network Functions.....	3-34
3.3.1 DHCP Function	3-34
3.3.2 File Transfer Function (FTP)	3-34
3.3.3 SNMP Function	3-35
3.3.4 Mail Transfer Function (SMTP)	3-36
3.3.5 HTTP Function	3-37
3.3.6 Communication Channel Function (/MC option).....	3-37
3.3.7 Modbus Function.....	3-38
3.3.8 SSL Communication Function.....	3-40
3.3.9 DARWIN Compatible Communication	3-42
3.3.10 EtherNet/IP Function (/E1 option)	3-44
3.3.11 WT Communication Function (/E2 option).....	3-45
3.3.12 Bluetooth Function (/C8 option)	3-46

3.3.13	Measurement/Setting Server Function	3-46
3.3.14	Advanced security function (/AS option)	3-46
3.3.15	Multi-batch Function (/BT option)	3-47
3.3.16	AEROSPACE HEAT TREATMENT (/AH option)	3-48
3.3.17	OPC-UA SERVER (/E3).....	3-49
3.3.18	SLMP COMMUNICATION (Mitsubishi PLC) (/E4).....	3-49
3.3.19	PID Control Function (PID), Program Operation Function (/PG Option)	3-50
3.3.20	Equipment/Quality Prediction Function (Release number 5 and later)	3-51
3.3.21	PROFINET Communication (Release number 5 (Version 5.02) and later).....	3-52

Revision Information.....	i
----------------------------------	----------

Using This Document

This document explains the features of the GM Data Acquisition System (hereafter referred to as the GM).

- This product is limited by the scan interval and the module to be used. For details, refer to the general specifications and user's manual.

Data Acquisition System GM General Specifications

GS 04L55B01-01EN

Data Acquisition System GM User's Manual

IM 04L55B01-01EN

■ Notes

- The content of this document is subject to change without notice as a result of enhanced performance and functions.
- If you find any inaccuracies or errors in this document, please contact Yokogawa.
- Any copy or reproduction of the content of this document, in whole or in part, without permission is prohibited.

■ Symbols Used in This Document

Aa#1

Indicates the character types that can be used.

A uppercase alphabet, **a** lowercase alphabet, **#** symbol,

1 numbers

■ Trademarks

- The Yokogawa product and brand names appearing in this document are trademarks or registered trademarks of Yokogawa Electric Corporation.
- The company trademarks and registered trademarks appearing in this document are not marked with TM or ®.
- All product names appearing in this document are trademarks or registered trademarks of their respective companies.

1. What Is SMARTDAC+ GM?

■ Overview

The SMARTDAC+ GM Data Acquisition System is a data logger that excels in versatility and expandability. The main unit contains memory for data acquisition and also supports SD cards for external storage.

The system consists of a Data Acquisition Module (GM10), Power Supply Module (GM90PS), and Module Base (GM90MB), which houses various modules. GM can operate with SMARTDAC+ series modules.



■ Features

- **Flexibly supports channel additions and reductions**
 - Measurement on up to 420 channels
 - Easy installation and reduction of modules with slide locks
- **Easy access from Web browser**
 - Hardware configuration
 - Real time monitoring
- **Mobile connection ready**
 - Bluetooth communication (/C8 option)
 - Monitoring and configuration from a tablet
- **High performance, high reliability**
 - Highly accurate measurement
 - Reliable data redundancy with internal memory and external storage medium
 - Auto backfill feature (Data Logging Software GA10)
- **Environmental and noise tolerance**
 - Wide operating temperature range: -20 to 60°C
 - A complete lineup of noise tolerant electromagnetic relay scanner type analog input modules

1.1 Functions That Ensure Reliable Measurements







The GM has four basic functions: measurement, recording, display, and storage. In addition, data can be used in various ways such as system configuration through the standard software (Hardware Configurator) and data file display (Universal Viewer). This section provides an overview of each function.

1.1.1 Rich I/O Interface

● Input

The GM can measure the following types of inputs.

The supported input types vary depending on the module. For details on the various input types, see section 3.1.1, "Measurement."

Input Type	
	DC voltage (DCV)
	Thermocouple (TC)
	Resistance temperature detector (RTD)
	On/Off (voltage-free contact, level), pulse
	DC current (mA) (direct input)
	DC current (through an external shunt resistor connection)
	Pulse

● Measurement

The GM samples the input signals at a specified scan interval and performs A/D conversion. These values become the measured values of each channel.

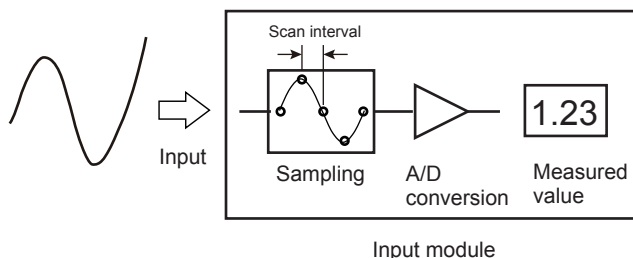

● Output (Relay output)

The GM can generate alarms assigned to measurement channels, turn the output on and off according to manual operation, and output relay signals through the event action function (digital output module, digital input/output module, PID control module).

For details on output, see section 3.1.3, "Output."

For the combinations of events and actions that can be used to output relay signals through the event action function, see section 3.2.2, "Event Action Function."

1.1.2 Actual Values Underlying Accurate Measurements

The measuring accuracies noted in the general specifications have a margin of error that takes into account the product's components and the equipment used for adjustment and testing. However, the actual values calculated from the accuracy testing data upon shipment of the instrument from the factory are as follows.

Input Type		Measuring Accuracy* (typical value)
DCV	20mV	$\pm (0.01\% \text{ of rdg} + 5 \mu\text{V})$
	60mV	$\pm (0.01\% \text{ of rdg} + 5 \mu\text{V})$
	6V(1-5V)	$\pm (0.01\% \text{ of reading} + 2 \text{ mV})$
TC	R, S	$\pm 1.1^\circ\text{C}$
	B	$\pm 1.5^\circ\text{C}$
	K (-200.0 to 1370.0°C)	$\pm (0.01\% \text{ of rdg} + 0.2^\circ\text{C})$ for 0.0 to 1370.0°C; $\pm (0.15\% \text{ of rdg} + 0.2^\circ\text{C})$ for -200.0 to 0.0°C
	K (-200.0 to 500.0°C)	$\pm 0.2^\circ\text{C}$ for 0.0 to 500.0°C; $\pm (0.15\% \text{ of rdg} + 0.2^\circ\text{C})$ for -200.0 to 0.0°C
	J	$\pm 0.2^\circ\text{C}$ for 0.0 to 1100.0 °C; $\pm (0.10\% \text{ of rdg} + 0.2^\circ\text{C})$ for -200.0 to 0.0 °C
	T	$\pm 0.2^\circ\text{C}$ for 0.0 to 400.0°C; $\pm (0.10\% \text{ of rdg} + 0.2^\circ\text{C})$ for -200.0 to 0.0 °C
	N	$\pm (0.01\% \text{ of rdg} + 0.2^\circ\text{C})$ for 0.0 to 1300.0 °C; $\pm (0.22\% \text{ of rdg} + 0.2^\circ\text{C})$ for -200.0 to 0.0 °C
RTD	Pt100 (-200.0 to 850.0°C)	$\pm (0.02\% \text{ of reading} + 0.2^\circ\text{C})$
	Pt100 (-150.00 to 150.00°C)	$\pm (0.02\% \text{ of reading} + 0.16^\circ\text{C})$

*1 Applies to GX90XA-10-U2, A/D integration time 16.67 ms or more, General operating conditions: 23±2 °C, 55±10% RH, supply voltage 90–132, 180–264 V AC, power frequency within 50/60 Hz ±1%, warm-up of 30 minutes or more, no vibrations or other hindrances to performance.

*2 For the measuring accuracy (guaranteed), see the module's general specifications (GS 04L53B01-01EN).

*3 These values do not include the reference junction compensation accuracy.
rdg: Reading value

- For details on modules with higher guaranteed accuracy specifications, contact your nearest YOKOGAWA dealer.

1.1.3 Fail-safe Saving of Recording Data

- **Data storage**

The GM supports long-term recording and multi-channel recording.

Measurement data is constantly saved in internal memory and can be transferred periodically to an external storage medium (SD card). Moreover, the FTP client function can be used to provide data redundancy using a file server. Measurement data is saved without fail even in a sudden power interruption.

Data can be saved automatically or manually to an external storage medium.

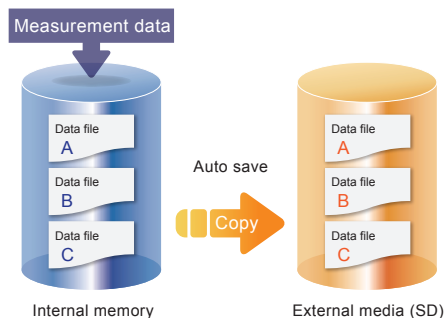

- **Data types**

Based on the sampled measurement values, the GM can record two types of measurement data: event data and display data (the data type depends on the GM settings).

Measurement data is saved to internal memory as data files.

For details, see section 3.1.2, "Recording."

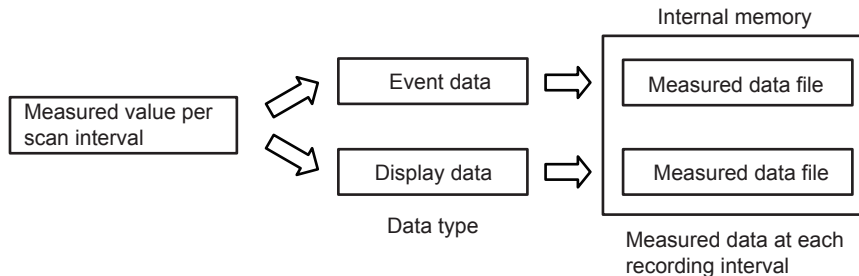

When the measurement mode is Dual interval, measured data of the channels assigned to measurement groups are recorded in the internal memory by each measurement group.

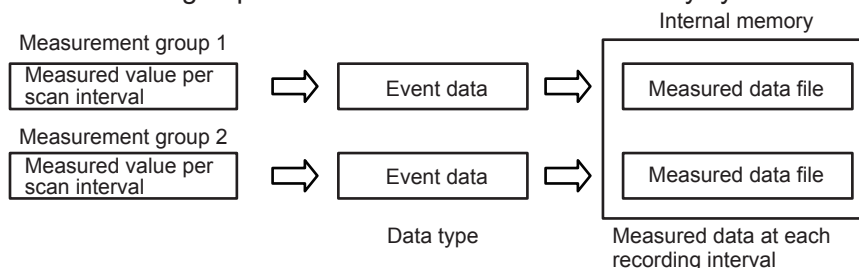

1.1.4 Easy Access from Web Browser

Data being measured can be monitored in real time on a Web browser. Using a network environment, you can monitor data over a wide area. You do not need to use a dedicated software application.

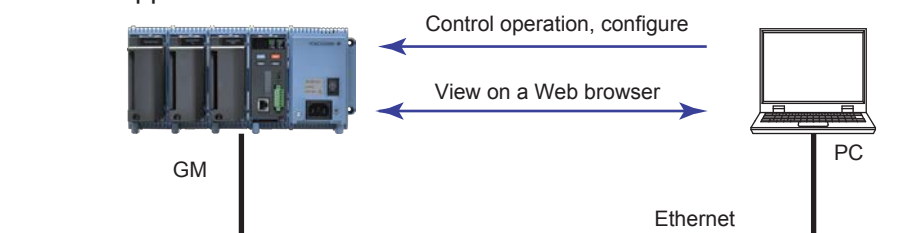

Web screen example

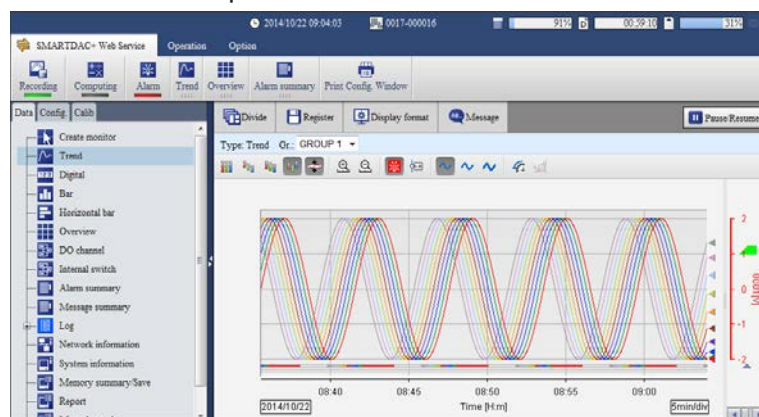

■ Configuration and Operation

You can configure the GM from a Web browser. You can also start and stop recording, write messages, and so on.

See section 3.1.5, "Display (Web browser)."

1.1.5 Offline Configuration and Monitoring

• Hardware Configurator

This software is used to transfer setup data to the GM and also save setup data. USB and Bluetooth connection is possible in addition to Ethernet connection.

Hardware Configurator

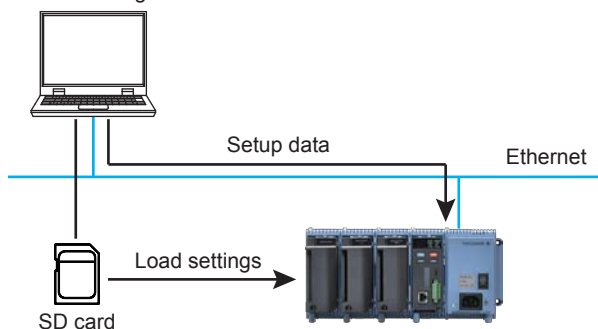

• Universal Viewer

This software is used to display measurement data files on a PC and print them. You can also calculate statistics on a specified set of data and convert data to ASCII and Excel formats.

• IP Address Configurator

This software is used to set the GM10's IP address, subnet mask, default gateway, and the like.

1.1.6 System Configuration Using Data Logging Software GA10 (Sold separately)

A dedicated software application for configuring a full-fledged system is available. This application is capable of acquiring data from multiple devices including SMARTDAC+ GM.

- Max. 100 devices
- 1 ms high-speed acquisition
- Max. 10000 channels (tags)

Data Logging Software GA10



1.2 A Full System Configuration Example

You can configure a GM system as shown below.

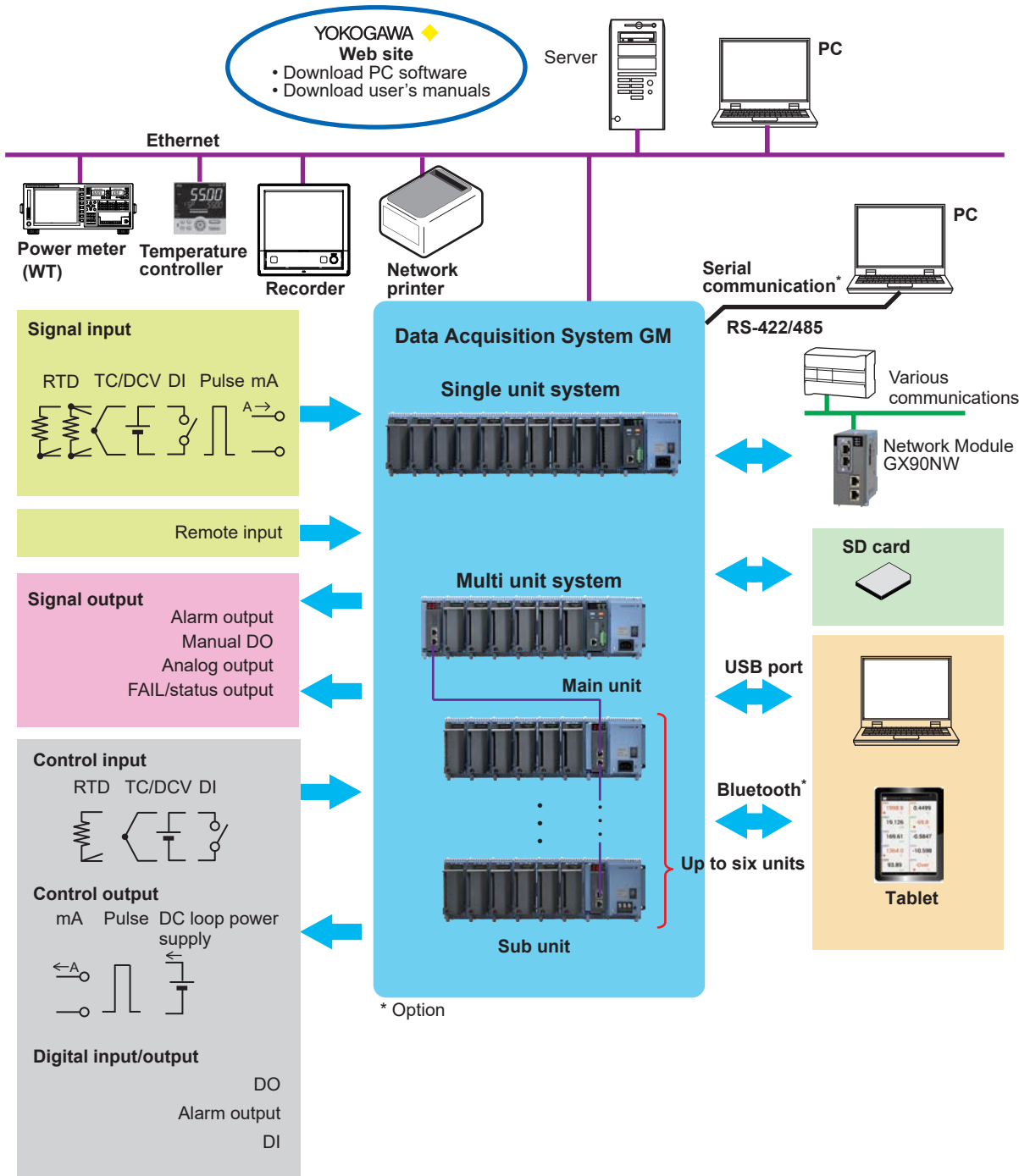

1.3 GM Application Examples

This section introduces main application examples in different industries.

■ Electrical and Electronic

● Performance evaluation testing of microwave ovens and IH cooking heaters

- The GM is used to acquire temperature data at multiple points to evaluate temperature distribution and ambient temperature.
- Measurement less susceptible to noise is possible by using electromagnetic relay type modules.

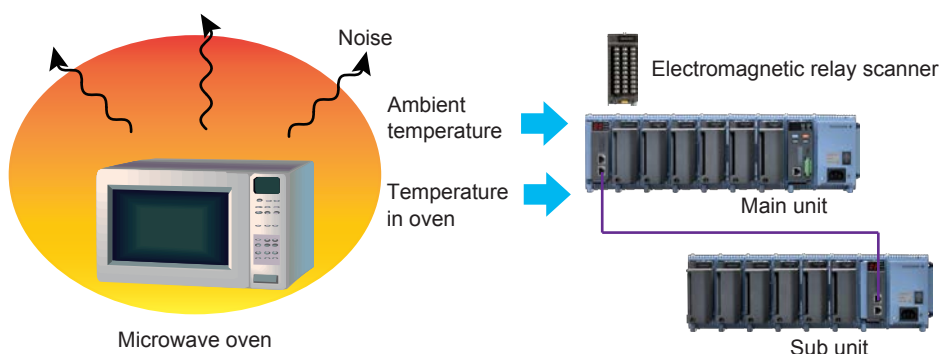

● Performance evaluation testing of washing machines

- The GM is used to acquire rotation, vibration, temperature, power consumption, and other types of data of washing machines.
- For power consumption, voltage, and current, the measurement data from WT power meters can be acquired in digital form, which preserves high-precision power measurements. (This requires the WT communication (/E2) option.)

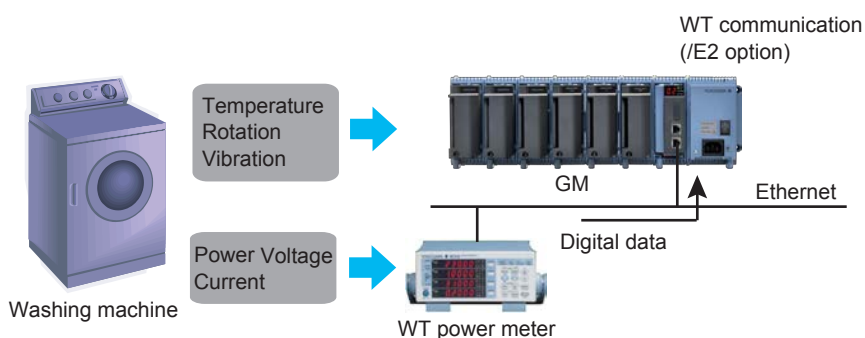

Vehicles

Car air conditioner evaluation

- The GM is used to acquire in-car temperatures, duct temperatures and humidities, supplied voltages, outside air temperatures, engine on/off state, and other types of data.
- The wide operating temperature range of -20 to 60°C enables testing in environmental test labs, hot and cold regions, and so on.
- Monitoring on a tablet is possible with the Bluetooth (/C8) option.

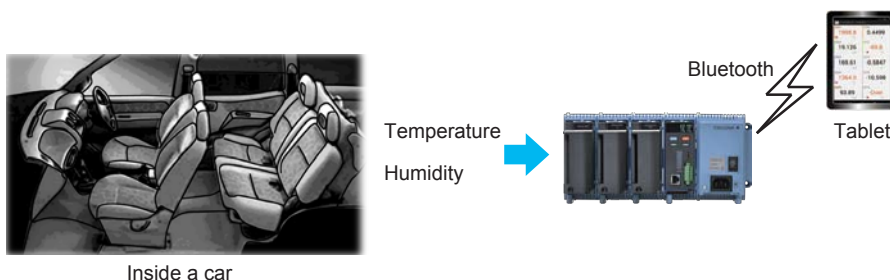

Engine durability testing

- The GM acquires various types of data, such as air temperature, water temperature, rotation, air volume, exhaust gas, in tests performed on engine test benches. Long-term data acquisition is possible such as in durability tests performed by supplying rotation and load control signals and varying the measurement conditions.
- Data acquisition is possible at different time intervals for each bench (multi-logging, (/BT option)) by using the Data Logging Software GA10.

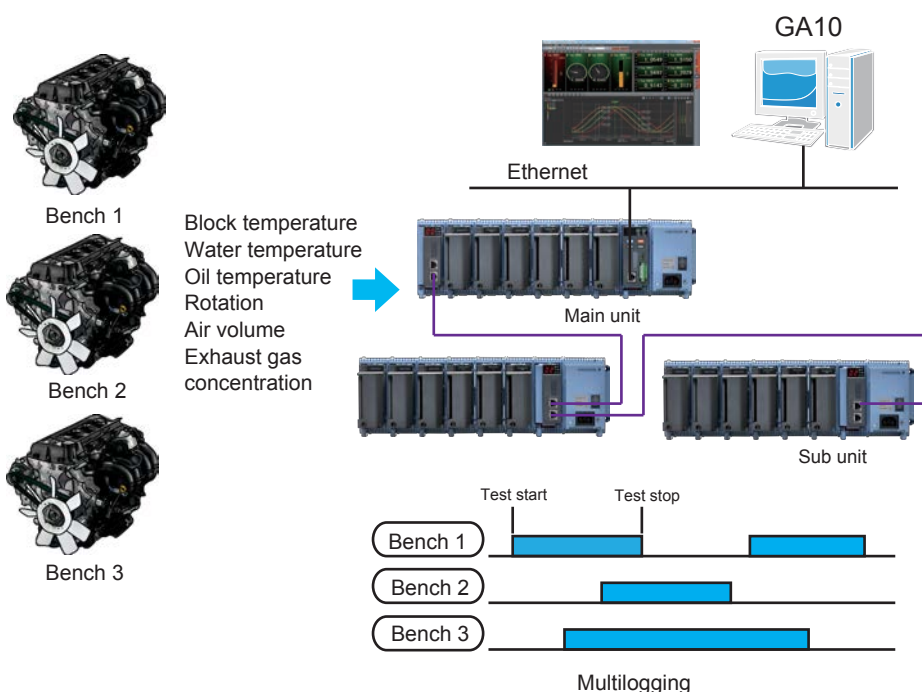

■ Environmental Monitoring

● Factory utility monitoring

- The GM is used to acquire and monitor various types of data, such as power, temperature, flow rate, PH, and residual chlorine concentration, from different utility equipment in factories.
- Equipment maintenance is possible based on the acquired data.

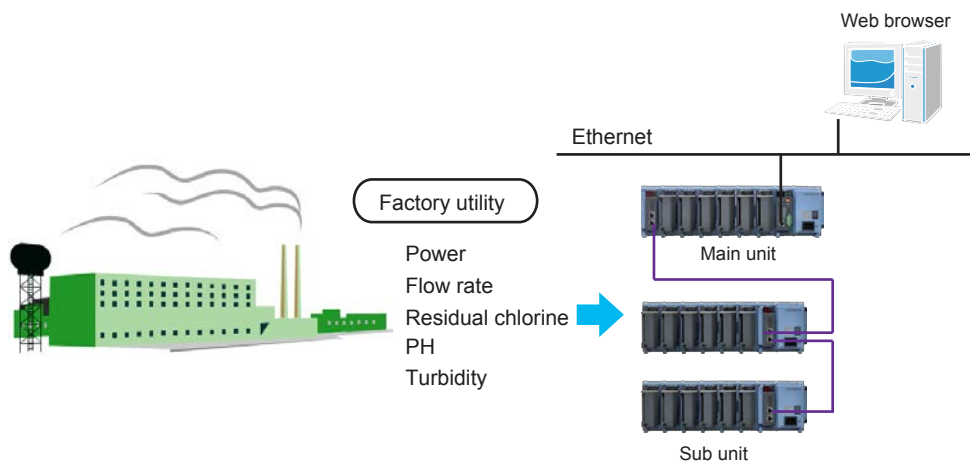

● Air conditioning monitoring in pharmaceutical labs and warehouses

- The GM is used to acquire and monitor the temperature, humidity, and the like in storage rooms for pharmaceuticals and foods and warehouses.
- Quality management is possible by acquiring trends and evaluating the effects to the quality of stored products.
- Monitoring on a tablet is possible with the Bluetooth (/C8) option.
- The advanced security function (/AS option) can be added to comply with 21 CFR Part11.

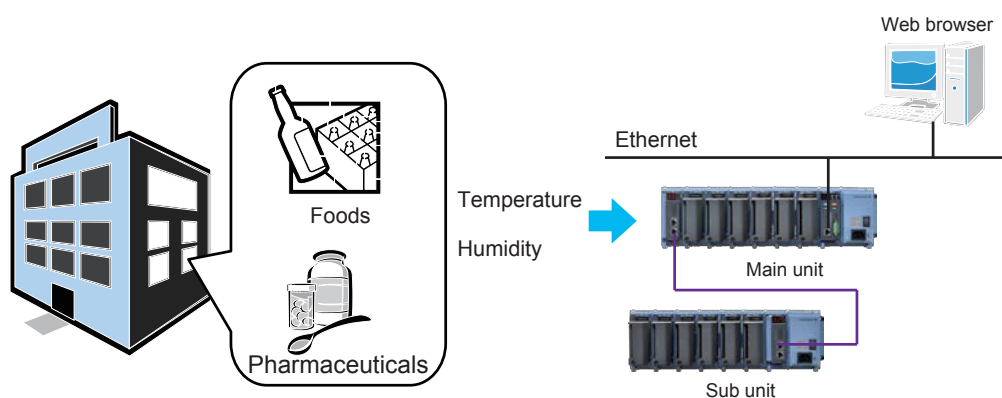

■ Plants

● Film coating process monitoring

- The GM is used to acquire and monitor the volume and components of photosensitizing agents, sheet feeding speeds, temperatures, humidities, the volume of bubbles, and the like.
- Performance and quality management of film is possible.
- Acquiring and monitoring of process data is easy with Data Logging Software GA10.

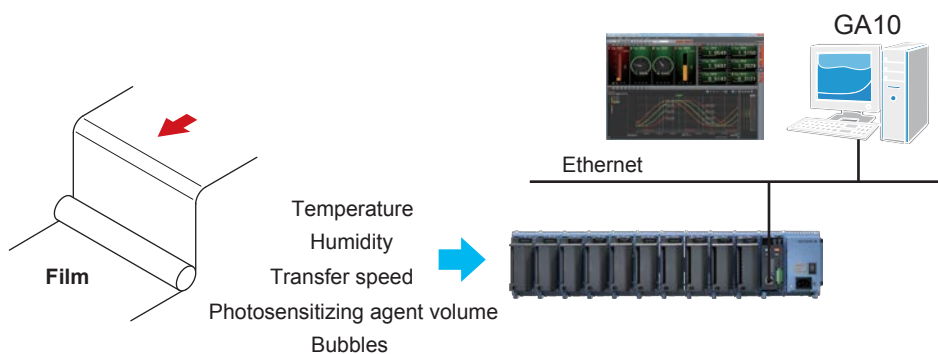

● Temperature distribution monitoring of melting furnaces

- The GM is used to acquire temperature data of melting furnaces, which can be monitored from a Web browser.
- Multi-point measurement of up to 100 channels is possible. (GM10-1)

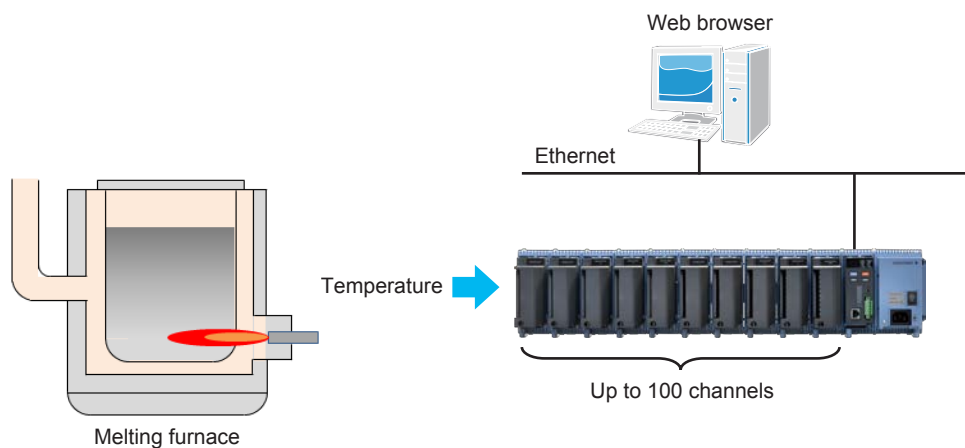



2. Scalable Data Acquisition System

2.1 Component Devices

A single GM unit consists a combination of the following modules and a module base. A data acquisition module is linked to the left of the power supply module, and input/output modules are linked on the left side of the data acquisition module.

A multi unit system (see the later explanation) is configured by linking expansion modules and connecting units over a LAN network.

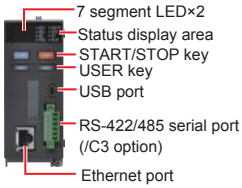
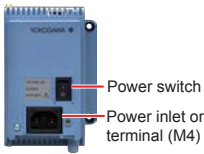
A module base is used to link a data acquisition module, input/output modules, and expansion module.

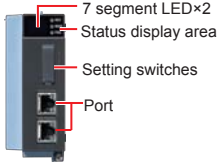
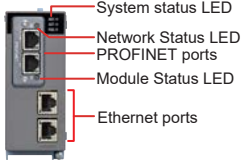
Name	Model	Component Names	Description
Data Acquisition Module	GM10		A module for acquiring data. It is linked to the left of the power supply module. (The position is fixed.) Only one module in a system.
Power Supply Module	GM90PS		A module for supplying power to the unit. Supply voltage: 100-240 V AC, 12-28 V DC
Input/output Module	GX90□□	—	A module for receiving and transmitting signals.
Module Base	GM90MB		A base is used to link a data acquisition module, input/output modules, and expansion module.
Expansion Module	GX90EX		A module for connecting units over a LAN network. An expansion module is installed in each unit to configure a multi unit system. The firmware version of the GX90EX that can be used with the GM must be R1.02.01 or later.
Network Module	GX90NW		For communication using industrial networks communication protocols. You can connect one network module to one main unit.

Input/output Module

Name	Model	Name	Model
Analog Input	GX90XA	Analog Output	GX90YA
Digital Input	GX90XD	PID Control	GX90UT
Pulse input	GX90XP		
Digital Output	GX90YD		
Digital Input/output	GX90WD		



Input/output modules may need to have their firmware updated.
For details, see the general specifications (GS 04L53B01-01EN, GS 04B53B01-31EN).
Analog Input Module Scan Intervals and Measurement Types

Type	Channels	Scan interval (fastest)	Scanner	TC	RTD	DCV	DI	mA	Resistance	Use
Universal (-U2)	10	100 ms	SSR	✓	✓	✓	✓			Universal
Low withstand voltage relay (-L1)	10	500 ms	SSR	✓			✓	✓		Low price
Electromagnetic relay (-T1)	10	1 s	Relay	✓			✓	✓		Noise tolerance
DC current (mA) input (-C1)	10	100 ms	SSR					✓		mA only
High withstand voltage (-V1)	10	100 ms	SSR	✓	✓	✓	✓			High withstand voltage
High-speed universal (-H0)	4	1 ms		✓	✓	✓	✓			High-speed universal
4-wire RTD/resistance	6	100 ms	SSR		✓				✓	4-wire RTD

2.2 Flexible Support for Channel Additions and Reductions

YOKOGAWA's original block structure (patented)

- Modules can be added one module at a time.
- Unique structure in which modules are linked to a module base
- Secure linking using a module base (slide lock mechanism; can also be fastened with screws)
- Module insertion and removal from the front, easy maintenance

The GM can be set up in a single unit system or multi unit system.

■ Max. 100 Channel Measurement Standard (Single unit)

This system consists only of a main unit for data acquisition.



■ Max. 420 Channel Measurement through Expansion (Multi unit)

This system consists of sub units connected to a main unit for data acquisition.

Up to six sub units can be connected.

The GM10-2 can be used to configure a 420-channel (input channel) system. Expansion modules are used to connect between the main unit and sub units and between sub units. Units are connected using Ethernet cables. The connections can extend up to 100 m total. Less wiring is possible by distribution such as when measurement locations are separated far apart.

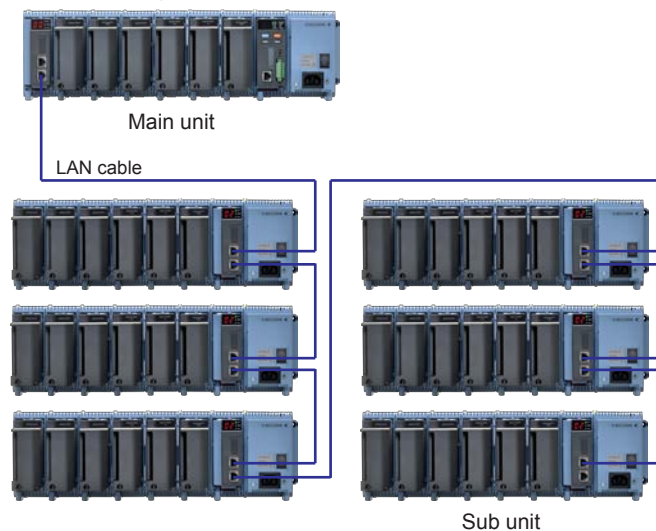

- * The main unit and sub units are connected directly using LAN cables. Hubs and repeaters cannot be used.

■ Less Wiring by Distribution

If the measuring site and the data logger installation location are far apart, a sub unit can be installed at the site to monitor the data without having to extend thermocouple and other signal wires over long distances.

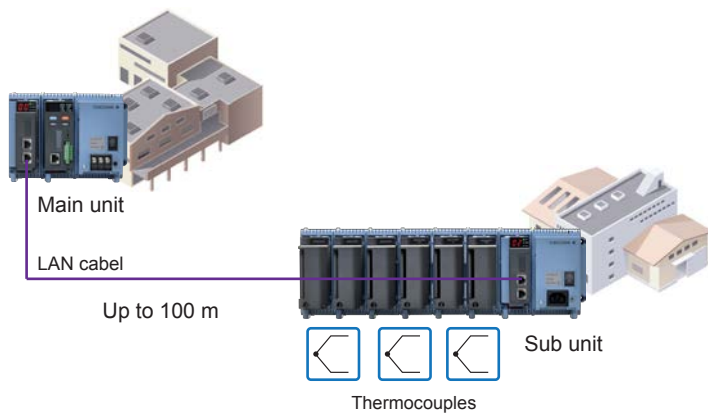

2.3 Unit Types and Configurations

There are two GM unit configurations: main unit and sub unit. A system consisting only of a main unit is called a single unit system; a system consisting of a main unit and sub units is called a multi unit system.

■ Main Unit

The main unit includes the data acquisition module.
Up to 10 input/output modules can be linked.

An expansion module (GX90EX) is linked to the left end when connecting to sub units.
In this case, the maximum number of input/output modules that can be linked is six.

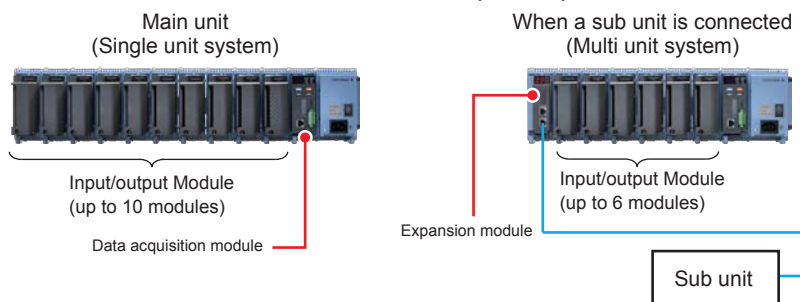

■ Sub Unit

A sub unit is connected to the main unit. An expansion module (GX90EX) is linked to connect to the main unit or other sub units with LAN cables. The maximum connection distance between two units is 100 m. Only cascaded connection is allowed; ring connection is not allowed. An expansion module is linked to the left of the power supply module, and input/output modules are linked on the left side of the data acquisition module. Up to six input/output modules can be linked.

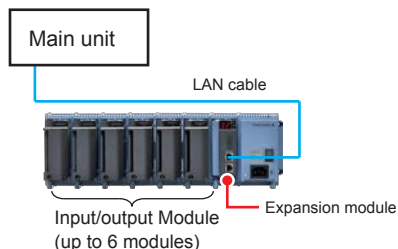

■ Notes on Connecting Modules

- See the GM10 Data Acquisition System First Step Guide (IM 04L55B01-02EN) and GM Data Acquisition System General Specifications (GS 04L55B01-01EN).

2.4 Flexible Installation Methods

The GM can be not only installed on a desktop but also mounted on a DIN rail or a wall. Special attachments are not necessary.

■ Desktop



■ DIN Rail Mounting

The GM can be mounted easily on a DIN rail using the latches on the rear of the module base.

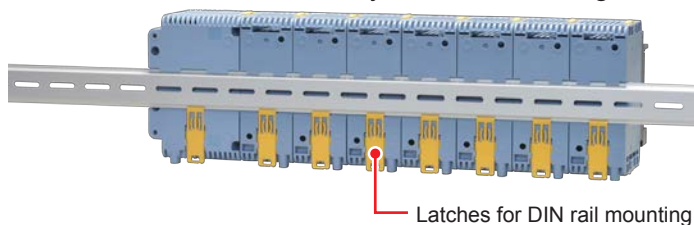

■ Wall Mounting

The GM can be mounted on a wall using the screw holes on the power supply module and module base.

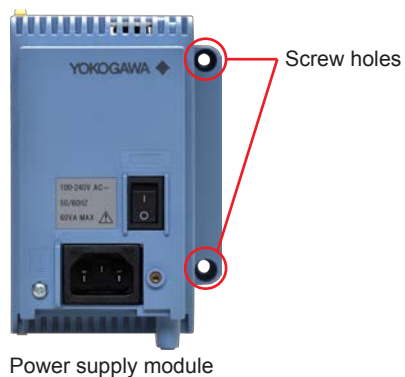
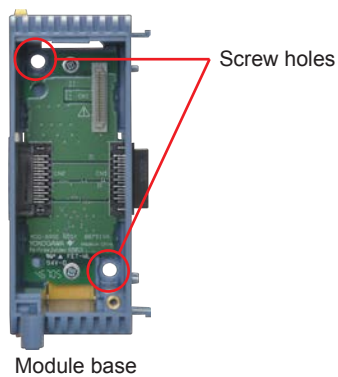
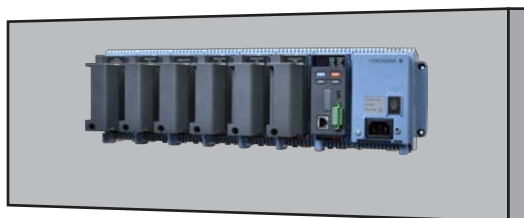

3. Functions

3.1 Basic Functions

3.1.1 Measurement

■ Input/output Types

A rich lineup of input/output modules are available.
You can select the best-suited module according to your measurement needs.



Input/output modules

Module	Model	Type	Number of Channels
Analog input	GX90XA	Universal, solid state relay, scanner type (-U2)	10
		Electromagnetic relay, scanner type (-T1)	
		Low withstand voltage relay, scanner type (-L1)	
		DC current (mA), scanner type (-C1)	
		High withstand voltage (-V1)	
		High-speed universal, individual A/D type (-H0)	4
		4-wire RTD/resistor, scanner type (-R1)	6
Digital input	GX90XD	—	16
Pulse input	GX90XP	—	10
Digital output	GX90YD	—	6
Digital input/output	GX90WD	—	Input: 8, Output: 6
Analog output	GX90YA	—	4
PID control	GX90UT	—	PID: 6, AI: 2, AO: 2, DI: 8, DO: 8

The following table shows the input types supported by each module.

Module	Type Suffix code	Input Type							
		DCV	GS	TC	RTD	DI ²	mA	Pulse ³	Resistance
Analog input	-U2	✓	✓	✓	✓	✓	✓ ¹		
	-T1	✓	✓	✓		✓	✓ ¹		
	-L1	✓	✓	✓		✓	✓ ¹		
	-C1						✓		
	-V1	✓	✓	✓		✓	✓ ¹		
	-H0	✓	✓	✓	✓	✓	✓ ¹		
	-R1				✓				✓
Digital input	—					✓		✓	
Digital input/output	—					✓		✓	
Pulse input module	—					✓		✓	
Analog output	—						✓		
PID control	—	✓	✓	✓	✓	✓	✓ ¹		

- 1 When an external shunt resistor is connected
- 2 Will be voltage or contact for analog input modules
- 3 Pulse input modules can receive also Level (5 V logic) signals.

Pulse measurement

Using digital input and digital input/output modules, you can measure pulses of flow rates, rain gauges, and the like (250¹ Hz max., minimum pulse width: 2 ms).

To perform pulse measurements, the GM10 needs to have the computation (/MT) option.

¹ When chattering filter is off. 125 Hz when chattering filter is on.

Using pulse input module, you can sum² pulses of flow rates, rain gauges, and the like (20KHz max., minimum pulse width: 25 μs).

² To perform pulse sum computation, the GM10 needs to have the computation (/MT) option.

Input Calculation

The following calculations can be performed on input signals.

Linear scaling

Converts the input value unit to obtain the measured value.

For example, linear scaling is used to convert the output signal from a temperature converter into temperature values.

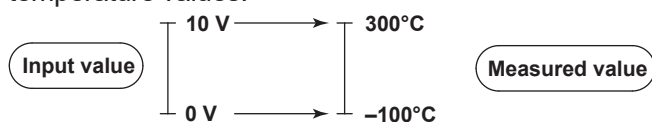

Delta

The measured value of the channel is set to the difference with respect to the measured value of the reference channel.

For example, this is useful when you want to measure the temperature difference in reference to the room temperature.

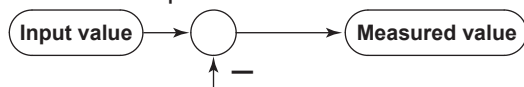

Measured value on the reference channel

Square root computation

Takes the square root of the input value and converts the unit to obtain the measured value.

In a differential pressure flowmeter, the output signal is proportional to the square of the flow rate. Therefore, to measure on a GM, square rooting is required.

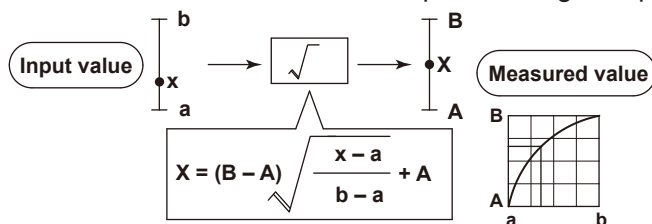

Low-cut

Set the low-cut value for square rooting.

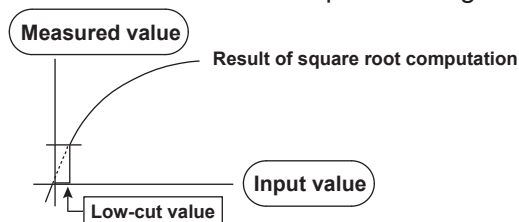

Log scale (/LG1)

The GM supports Log input, pseudo log, and log linear input.

For details on the function, see section "3.2.1 Alarm Function" on page 3-15.

Other Types of Input Processing

Moving average

Performs moving average over the specified number of sampling points.

For example, you can use this to smooth the data when the input signal is fluctuating due to noise or other unwanted influences.

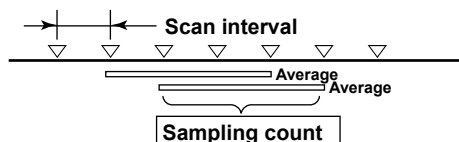

Bias

This is used to add a constant value to input values or scaled values (input computation).

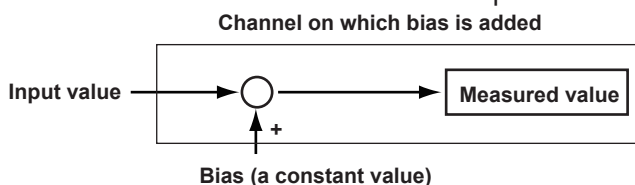

Calibration correction

Input values can be corrected using segment linearization. Up to 12 correction points can be specified.

Linearizer approximation

Corrects input values using characteristics specified with segments to derive output values.

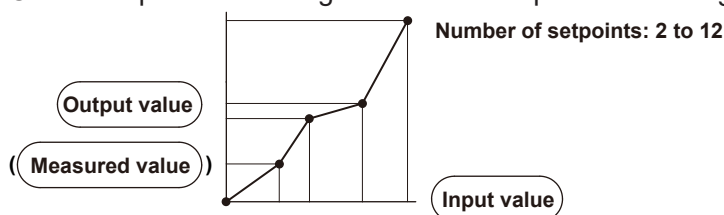

Linearizer Bias

Corrects input values using bias values specified with segments to derive output values.

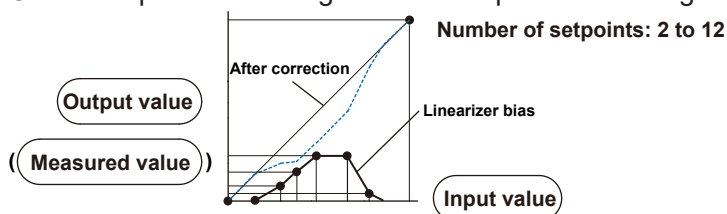

Correction factor

Corrects input values using the instrument correction factor and sensor correction factor specified with segments to derive output values.

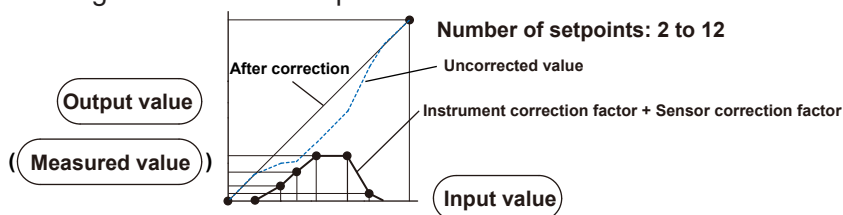

■ Scan Interval

This is the interval at which the input signal is sampled and converted into digital values (A/D conversion). You can select from 1 ms, 2 ms, 5 ms, 10 ms, 20 ms, 50 ms, 100 ms, 200 ms, 500 ms, 1 s, 2 s, and 5 s. The scan intervals that you can set vary depending on the module. If modules with different shortest scan intervals are present in the system, the shortest scan interval that you can set is the shortest scan interval of the slowest module.

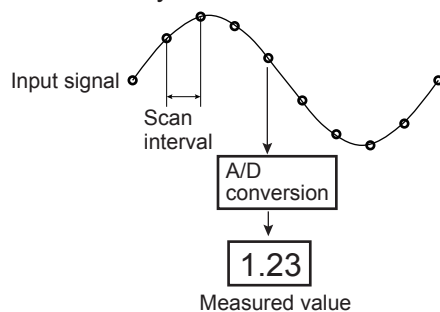

Shortest scan intervals by analog input module suffix codes

Module	Type	Number of Channels	Shortest Scan Interval
GX90XA analog input	Universal (-U2)	10	100 ms
	Low withstand voltage relay (-L1)	10	500 ms
	Electromagnetic relay (-T1)	10	1 s
	DC current input (-C1)	10	100 ms
	High withstand voltage (-V1)	10	100 ms
	High-speed universal (-H0)	4	1 ms
	4-wire RTD/resistance (-R1)	6	100 ms

A/D Integration Time

The GM uses an A/D converter to convert sampled analog signals to digital signals. By setting the integration time of the A/D converter to match the time period corresponding to one cycle of the power supply or an integer multiple of one cycle, the power supply frequency noise can be effectively eliminated.

Common (36.67 ms/100 ms) can be specified to effectively eliminate power supply frequency noise for both 50 Hz and 60 Hz.

Note that the selectable A/D integration times vary depending on the scan interval settings.

Integration Time	Explanation			
Auto	The GM automatically detects the power supply frequency and sets the integration time to 16.67 ms for 60 Hz and 20 ms for 50 Hz. However, if the module operation mode is 10ch and the scan interval is 100 ms or 200 ms, the A/D integration time is fixed at 1.67 ms.			
50Hz	Sets the integration time to 20 ms.			
60Hz	Sets the integration time to 16.67 ms.			
Common	Sets the integration time to 16.67 ms, 20 ms, 36.67 ms, or 100 ms. Integration time and scan interval by module			
	Type	Integration Time	Scan Interval	
			10ch mode	2ch mode
	Universal, DC current input High withstand voltage	36.67 ms	1s	
		100 ms	2 s or 5 s	
	Electromagnetic relay	16.67 ms/20 ms	1s	—
		36.67 ms	2s	—
100 ms		5s	—	
Low withstand voltage relay	36.67 ms	2s	—	
	100 ms	5s	—	

■ Measurement Mode

By switching the measurement mode according to the measurement target and measurement conditions, you can perform high-speed measurements as well as simultaneous high-speed and low-speed measurements.

● High-speed measurement at the shortest measurement interval of 1 ms

Measurement at the shortest interval of 1 ms is possible by using a high-speed analog input module equipped with an original A/D converter developed by YOKOGAWA.

● Dual interval measurement

Two different scan intervals can be used together in a single system. Slow changing signals such as temperature and fast changing signals such as pressure and vibration can be measured simultaneously and efficiently. Scan groups are specified on each module.

Reference Junction Compensation (RJC)

Performs reference junction compensation on thermocouple input. You can select whether to perform reference junction compensation internally within GM or externally (with a reference junction compensator).

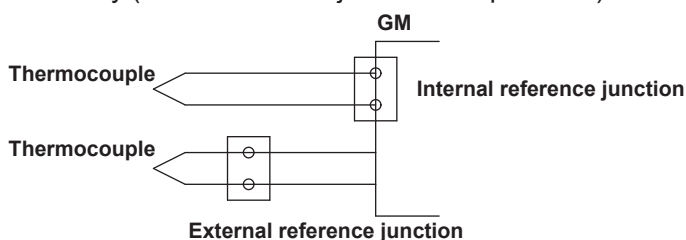

Burnout Detection

When the range type is set to thermocouple (TC), resistance temperature detector (RTD) or standard signal (GS (1-5V), GS (4-20 mA)), the GM detects sensor burnouts. If the range type is set to GS (1-5) or GS (4-20 mA), you can set the upper and lower limits for determining burnouts.

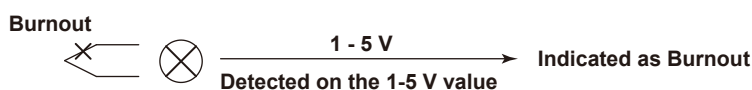

Burnout limits (for GS (1-5V), GS (4-20 mA) ranges)

Item	Selectable Range (Percentage of the specified span width)
Lower Limit of Burnout	-20.0 to -5.0%
Upper limit of burnout	105.0 to 120.0%

Operation Modes of Modules

AI modules

2ch mode and 10ch or 6ch mode are available.

In 10ch mode, measurement is possible on CH1 to CH10.

In 6ch mode, measurement is possible on CH1 to CH6.

In 2ch mode, measurement is possible only on CH1 and CH2. (CH3 and higher channels are fixed to Skip.)

In 10ch mode, when the scan interval is 100 ms or 200 ms, the A/D integration time is fixed at 1.67 ms. Since the power frequency noise is not eliminated, the measured values may fluctuate, especially in temperature measurements using thermocouples. In 2ch mode, when the scan interval is 100 ms or 200 ms, the A/D integration time is 16.67 ms or 20 ms. This allows power frequency noise to be eliminated.

Note that the selectable A/D integration times vary depending on the 2ch/6ch/10ch mode and scan interval settings.

For the high-speed AI module, power frequency noise is rejected using the noise rejection feature.

- **DI modules**

Normal and remote operation modes are available.

For normal DI input, specify Normal.

Specify Remote to use the DI module as a remote control input.

When there are multiple DI modules, only one of them can be set to Remote.

Remote can only be specified for a DI module or DI/DO module installed in the main unit.

To use remote control through event action, select Remote.

3.1.2 Recording

■ Recording Interval

The recording interval is the interval at which data sampled at the scan interval is recorded as measurement data.

For details on the methods for recording event data and display data, see the next page.

- **Event data**

Set the interval at which to record measurement data.

You cannot choose a recording interval that is shorter than the scan interval.

- **Display data**

The recording interval of display data is determined by the trend interval [/div] setting.

The GM records the maximum and minimum values from within the data sampled at the scan interval within the recording interval.

■ Data Types

The GM can record the following types of data.

Data Types	Explanation
Event data	<ul style="list-style-type: none"> • Measurement data that is recorded at the specified recording interval. There are two modes. One mode starts recording when a trigger occurs. The other mode records at all times. • A header string (shared with other files) can be written in the file. • Contains alarm and message information. • Data format: Binary and text
Display data	<ul style="list-style-type: none"> • Measurement data that records the maximum and minimum values of the sampled data within the recording interval, which is determined by the specified trend interval. • A header string (shared with other files) can be written in the file. • Contains alarm and message information. • Data format: Binary and text
Manual sampled data	<ul style="list-style-type: none"> • Instantaneous value of the measured data when a manual sample operation is executed. • A header string (shared with other files) can be written in the file. • Data format: Text
Report data (/MT option)	<ul style="list-style-type: none"> • Hourly, daily, weekly, monthly, batch, daily custom report data. Report data is created at an interval that is determined by the report type (one hour for hourly reports, one day for daily reports, and so on). • A header string (shared with other files) can be written in the file. • Data format: Text • The data can be converted to Excel and PDF formats.
Setting parameters	<ul style="list-style-type: none"> • The setting parameters of the GM. • Data format: Text

■ Methods for Recording Event Data and Display Data

This section explains the methods for recording event data and display data.

● Event data

The GM records the data sampled at the scan interval at the specified recording interval. Detailed data is recorded, but the data size becomes large.

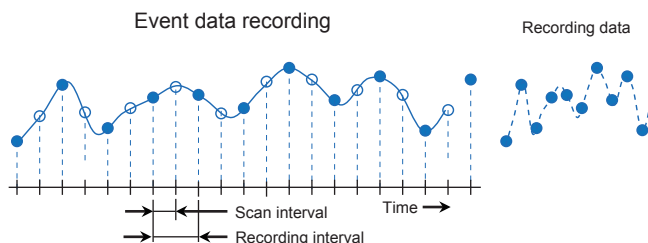

● Display data

Display data can be likened to recording to chart paper on conventional pen recorders. Using the data sampled at the scan interval, the GM records the maximum and minimum sampling data values within each recording interval (interval determined by the trend interval $[div]$). Detailed data of each sample is not retained, but because the maximum and minimum data values are recorded, display data expresses the fluctuation range in each recording interval. In addition, because the number of data values can be reduced, display data allows long-term data recording to the internal memory.

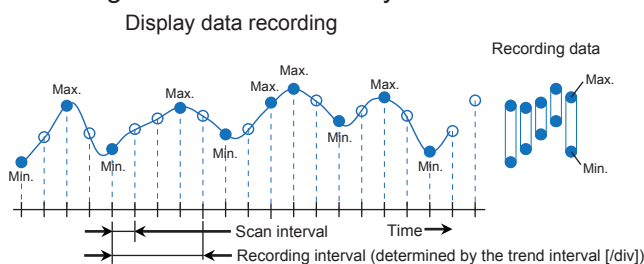

Recording interval of display data

The recording interval of display data is determined by the trend interval $[div]$ setting. The relationship between the trend interval and the recording interval is shown below.

Trend Interval	5s	10s	15s	30s	1min
Recording Interval	100ms	200ms	500ms	1s	2s
Trend Interval	2min	5min	10min	15min	20min
Recording Interval	4s	10s	20s	30s	40s
Trend Interval	30min	1h	2h	4h	10h
Recording Interval	1min	2min	4min	8min	20min

Event Data Recording Modes

The following event data recording modes are available.

Free

Recording starts when you start it and stops when you stop it. Measurement data is divided by the specified duration (data length).

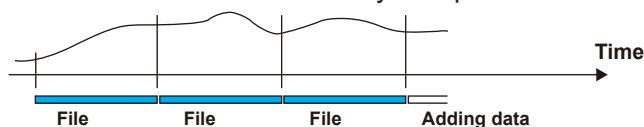

Data length

Set the size of recording data per file. Recording data is divided at the specified file size. The selectable data lengths vary depending on the number of channels to record and the Scan interval setting.

Single

The GM enters the trigger-wait state when you start recording. After a trigger event occurs, the GM will record data for the specified time (data length) and stop. From this point, the GM will not record even if the trigger condition is met.

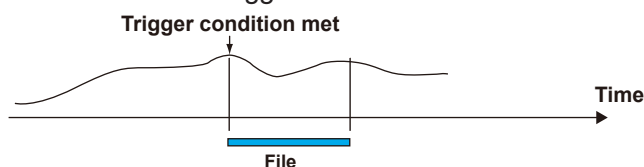

Repeat

The GM enters the trigger-wait state when you start recording. After a trigger event occurs, the GM will record data for the specified time (data length) and stop. Then, it enters the trigger-wait state again and repeats recording for the specified time (data length) every time the trigger condition is met. To stop recording event data, stop the recording.

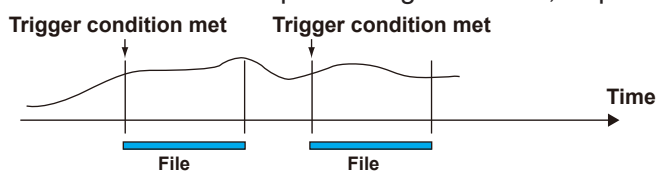

Internal Memory

The recorded measurement data is divided at a specific time interval (data length for event data and file save interval for display data) and saved to files.

If the internal memory is full or if the number of display data files and event data files exceeds 500 for the GM10-1 or 1000 for the GM10-2, files are overwritten from the oldest file.

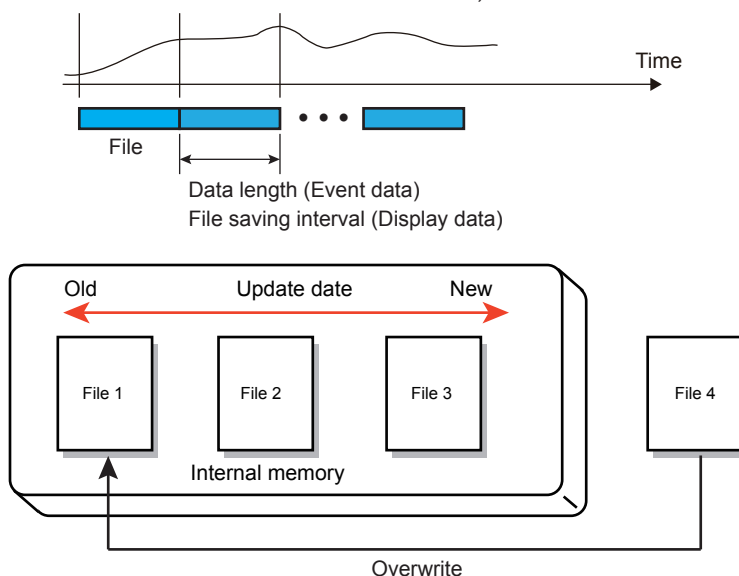

Recording Channels

Set the channels for recording the measurement data of event data, display data, and manual sampled data.

Only the channels assigned to recording channels are recorded as measurement data.

You can select the channels to record from AI channels, DI channels, pulse input channels, DO channels, math channels (/MT option), and communication channels (/MC option).

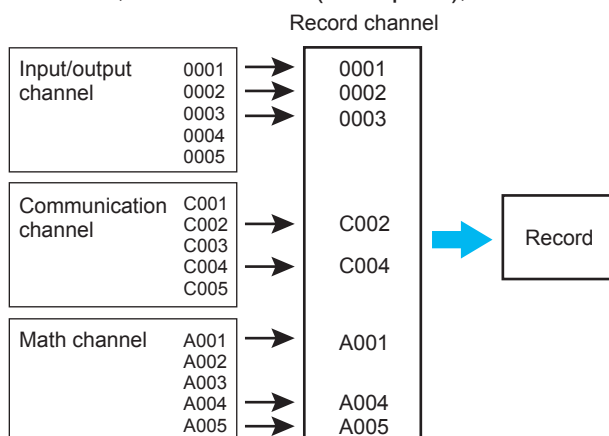

Number of recording channels

Data Type	Maximum Number of Recording Channels	
	GM10-1	GM10-2
Event data	500ch (250ch)*	1000ch (600ch)*
Displat data	500ch (250ch)*	1000ch (600ch)*
Manual sampling data	50ch	100ch

* Numbers in parentheses are for when the measurement mode is set to Dual interval.

The maximum number of channels that the GM can record varies depending on the recording interval and recording data type (for the GM10-2).

3.1.3 Output

The GM can output relay signals (digital output module or digital input/output module) when an alarm occurs, when a failure occurs, when they are manually turned on, or according to the event action function.

The output (DO channel) can also be recorded.

Digital output module

Module	Model	Output type	Number of Channels
Digital output	GX90YD	Relay, SPDT(NO-C-NC)	6
Digital input/output	GX90WD	Relay, SPDT(NO-C-NC)	6

● **Alarm output**

When an alarm assigned to a measurement channel occurs, a relay signal is output from the DO channel that the alarm output is assigned to.

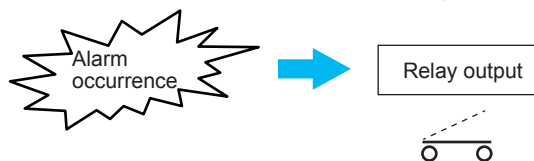

● **Manual output**

DO channels can be turned on and off through manual operation on the digital display screen shown in the Web browser.

To use manual output, the following settings are required.

- Set the DO channel type to Manual.
- In Display settings, set Value Modification from the Monitor to On.



● **Event action**

A relay signal is output when an event occurs.

For the events that can use relay output, see section "3.2.2 Event Action Function" on page 3-18.

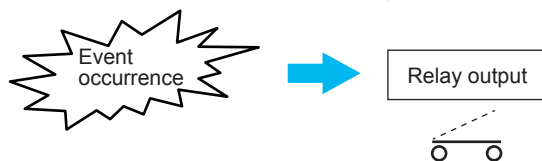

3.1.4 Storage

Measurement data saved in the internal memory can be saved in an external storage medium (SD card) automatically or manually.

■ Auto Save

Measurement data in the internal memory is saved automatically to an external storage medium (SD card).

Keep the SD card inserted in the drive at all times.

● Media FIFO Function

If not enough free space is available when saving a new data file to the SD card, files are deleted in order from the oldest data update date/time to save the new file. This operation is referred to as FIFO (first in first out).

When saving the data files automatically, you can save the data so that the most recent data files are constantly retained in the SD card. This method allows you to use the GM continuously without having to replace the SD card.

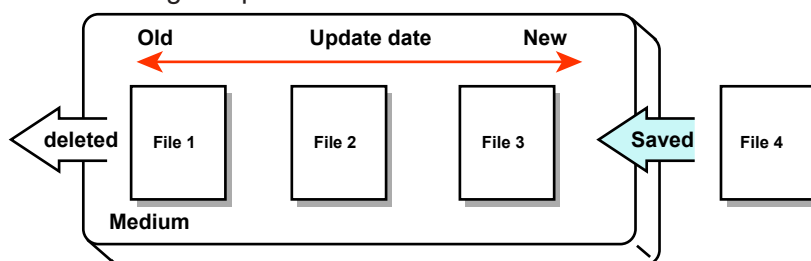

● Media FIFO Save Operation

- Up to the most recent 1000 files are retained. If the number of files in the save destination directory exceeds 1000, the number of files is held at 1000 by deleting old files even if there is enough free space.
- If there are more than 1000 files already in the save destination directory, at least one file is always deleted before saving the new file. The number of files is not kept within 1000 in this case.
- FIFO is used only when the following files are saved automatically. When files are saved using other methods, FIFO is not used.

Data File Types
Display data file
Event data file
Report data file
Manual sampled data file

■ Manual Save (Collectively Storing Unsaved Data)

If you do not use the auto save function, save measurement data manually.

Unsaved data in the internal memory is stored in files to the external storage medium (SD card) when an external storage medium is inserted.

When using manual save, you must be careful to save the data in the internal memory to the external storage medium before the data is overwritten.

■ Measurement Data File Format

Measurement data can be saved in binary or text format.

● Binary format

If security is a priority, save the measurement data in binary format.

It is extremely difficult to decipher or tamper binary data using a typical text editor.

● Text format

If you want to directly open the data with a general-purpose text editor, spreadsheet application, or the like, save the data in text format. You will be able to edit the data without using a dedicated software application.

3.1.5 Display (Web browser)

Real time monitoring of measurement data is possible from a Web browser. You do not need to use a special software application.

You can also configure the GM and perform operations such as recording start/stop and computation start/stop.

■ Monitoring

You can monitor data being measured on the trend, digital, bar graph, overview, and other screens. In addition, past data can be displayed (historical trend).

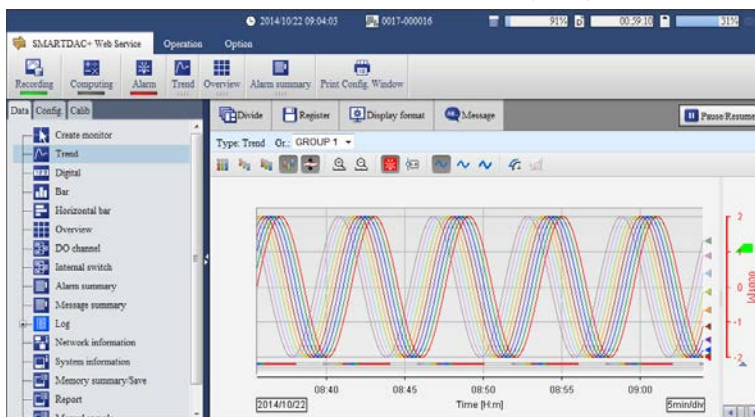

■ Operation

You can perform operations such as recording start/stop, computation start/stop, message writing, and manual sampling.

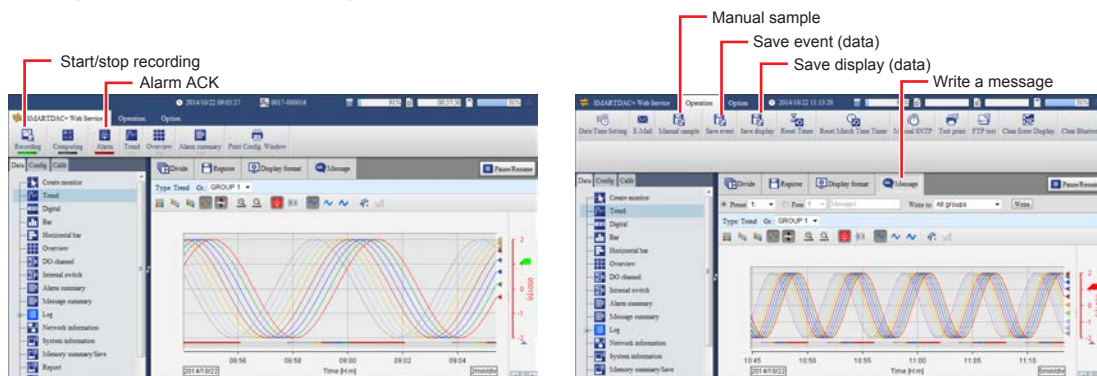

● **Message writing**

Messages can be written in event data and display data.

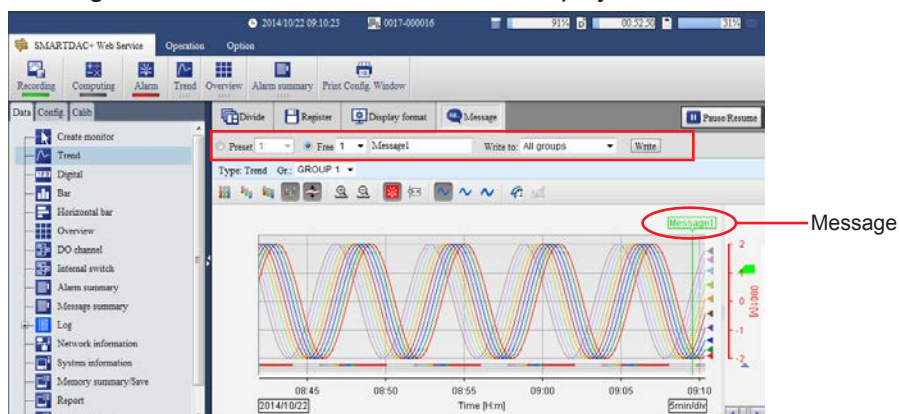

Types of messages that can be written

Message Type	Explanation
Preset message	You can write preset messages. Number of displayable characters: Up to 32 Up to 100 messages can be registered.
Free message	You can write messages that you enter freely. There are 10 free messages. The messages that you enter are registered in free messages 1 to 10.
Auto message	When the GM recovers from a power failure during recording, a fixed message is written.

■ **Configuration**

You can configure the GM from a Web browser.

When a configuration change occurs, you can simply switch to the Config. tab and change the settings; you do not have to use the configuration software.

In addition, you can perform system reconfiguration and A/D calibration from the Calib tab.

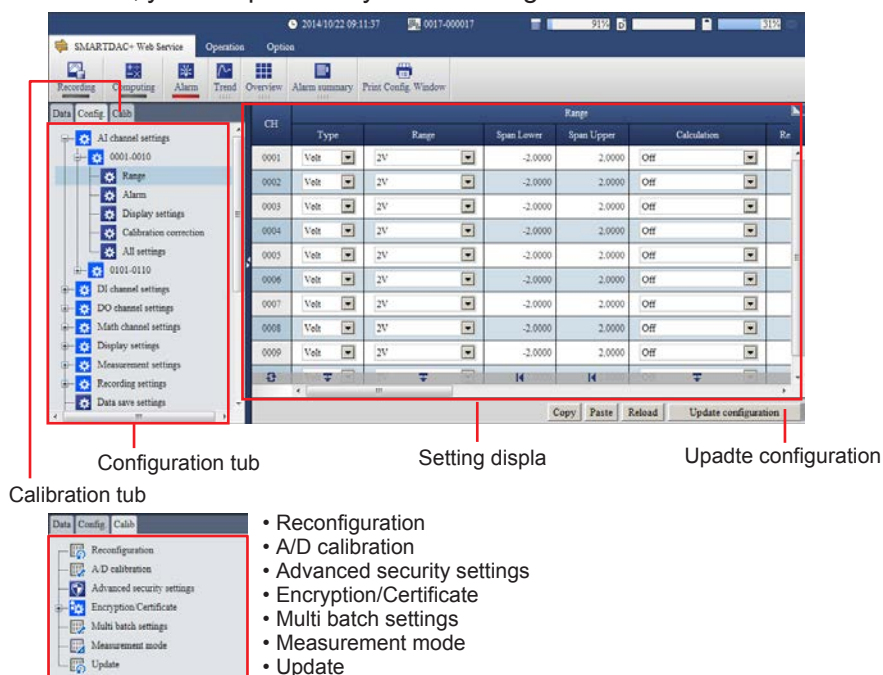

3.2 Various Functions

3.2.1 Alarm Function

For the measured values, up to four levels of alarms can be set on each channel.

Alarms can be output to relays and internal switches.

The alarm types that you can set vary depending on the channel type (input/output, math, communication).

■ Alarm Types

Type	Explanation	
High limit (H)	An alarm is activated when the measured value is greater than or equal to the alarm value.	
Lower limit (L)	An alarm is activated when the measured value is less than or equal to the alarm value.	
High limit on rate-of-change (R)	An alarm is activated if the increasing rate-of-change of measured values over a certain interval is greater than or equal to the specified value.	
Low limit on rate-of-change (r)	An alarm is activated if the decreasing rate-of-change of measured values over a certain interval is greater than or equal to the specified value.	
Delay high limit (T)	An alarm is activated if measured values remain greater than or equal to the alarm value for a specified time period (delay period).	
Delay low limit (t)	An alarm is activated if measured values remain less than or equal to the alarm value for a specified time period (delay period).	

Continued on next page

Type	Explanation	
Difference high limit (h)	An alarm is activated when the difference in the measured values of two channels is greater than or equal to the specified value. This alarm can be specified on measurement channels set to difference computation.	
Difference low limit (l)	An alarm is activated when the difference in the measured values of two channels is less than or equal to the specified value. This alarm can be specified on measurement channels set to difference computation.	
Profile high limit (F)	An alarm is activated when the measured value is greater than or equal to the profile trend high limit. You can set this when the profile trend is set to On.	
Profile low limit (f)	An alarm is activated when the measured value is less than or equal to the profile trend low limit. You can set this when the profile trend is set to On.	

The character inside the parentheses is the symbol denoting each alarm.

Alarm of a channel set to difference computation
It is set in the position shown in the figure below.

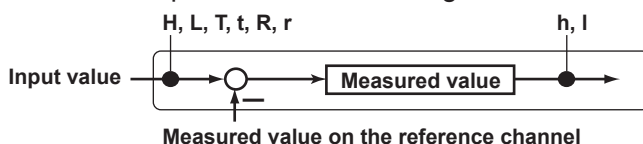

■ Hysteresis

You can furnish an offset between the value used to activate and release alarms. This is fixed at 0 for the DI range.

Example:

H: If you set the alarm value of a high limit alarm to 1.0000 V and the hysteresis to 0.0005 V, an alarm is activated when the measured value is greater than or equal to 1.0000 V and is released when the measured value is less than 0.9995 V.

■ Alarm Display (Detection)

You can select whether to display an alarm (indicate the occurrence) when an alarm occurs. If the alarm display is disabled, when an alarm occurs, the GM outputs signals to alarm output DO channels or internal switches but does not display the alarm. In addition, alarms are also not recorded in the alarm summary.

■ Changing the Alarm Values from the Web Page

You can change the alarm values from the Monitor Page (digital, bar graph, overview) on the Web browser.

This is useful when you need to change the alarm values depending on measurement conditions. To use this function, in Display settings, under Screen display settings, Changing each value from monitoring must be set to On.

■ DO Output Operation

● AND/OR Operation

When multiple alarms are assigned to one alarm output relay, you can select which condition below will activate the output relay. You can also specify AND operation for internal switches.

- AND: Activated when all assigned alarms are occurring simultaneously
- OR: Activated when any of the specified alarms is occurring

● Reflash

When multiple alarms are assigned to one alarm output relay, this function notifies the occurrence of subsequent alarms after the relay is activated by the first alarm. When subsequent alarms occur, the output relay is released temporarily. The duration for which the relays are deactivated can be set to 500 ms, 1 s, or 2 s.

Relays set to Reflash will operate using OR and Nonhold settings.

● Energize or De-energize Operation

You can select whether the alarm output relay is energized or de-energized when an alarm occurs. If you select de-energize, the alarm output relays will be in the same state when the GM is shut down as they are when an alarm occurs.

● Non-hold/Hold

The alarm output relay can be set to operate in the following fashion when the alarm condition is no longer met.

- Turn OFF the relay output (nonhold).
- Hold the relay at ON until the alarm ACK is executed (hold).

● Alarm Acknowledge Operation (Alarm ACK)

Acknowledging All Alarms

Releases all alarm indications and relay outputs.

Individual Alarm ACK

You can release specific alarms.

In System settings, under Alarm basic settings, Individual Alarm ACK must be set to On.

DO Output Relay Operation

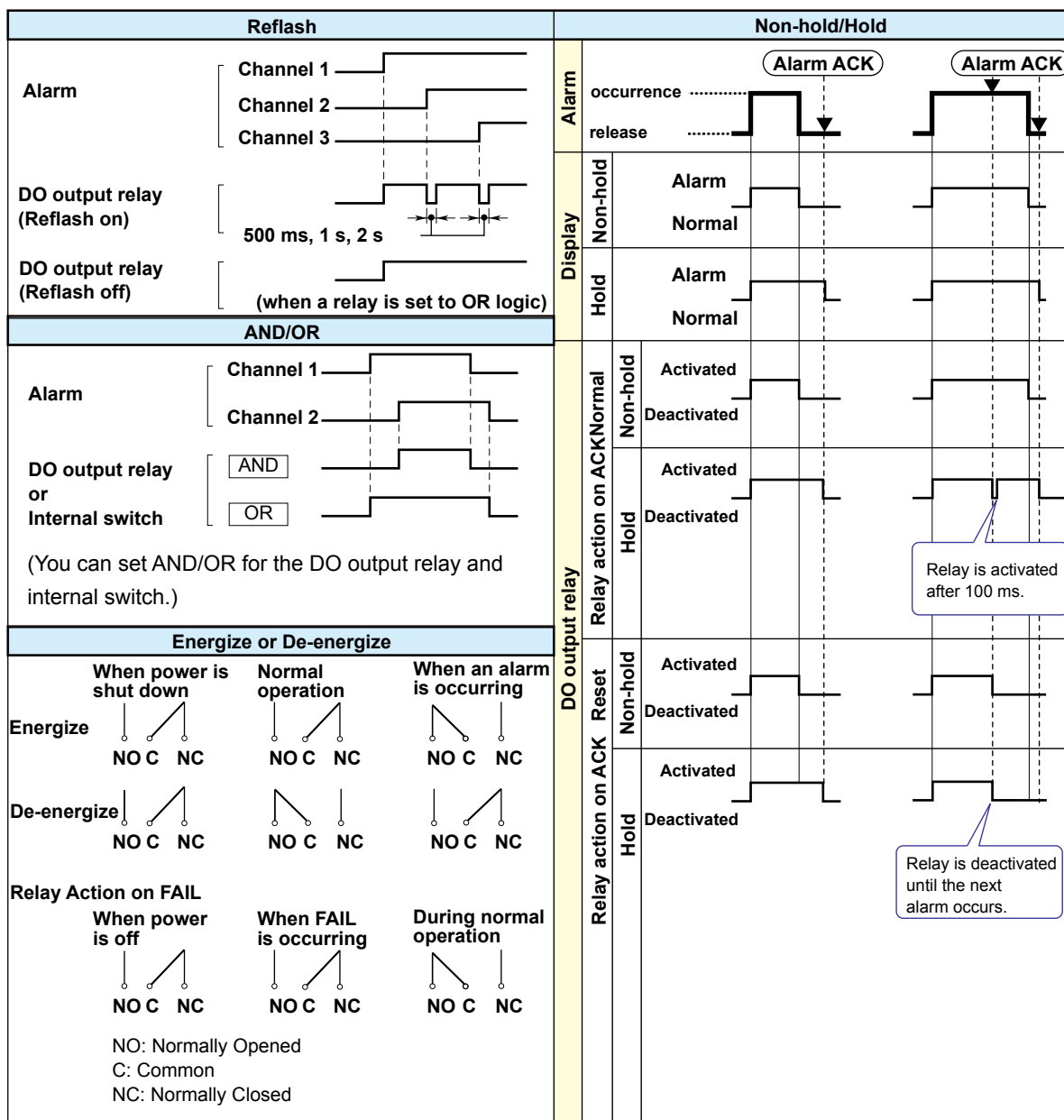

3.2.2 Event Action Function

The event action function is used to execute specified actions when certain events occur. It can also be used to perform remote control.

For example, you can have the GM write a message in the measurement data when an alarm occurs or start recording on a remote control input.

You can set up to 50 event actions (event action number 1 to 50).

■ Event Types

Item	Explanation
Remote (DI)	DI channel of remote control input
Relay (DO)	Relay status
Internal switch	Internal switch status
Alarm - IO channel	Alarm of an I/O channel
Alarm - Math channel	Alarm of a math channel
Alarm - Communication channel	Alarm of a communication channel
Any alarm	The change from no active alarms to one or more active alarms is regarded as an event.
Health score notification	An event that occurs when the health score falls to a negative value, or below the set early warning notification threshold.
Timer	Timer (timer 1 to 12) expiration
Match Time Timer	Match time timer (match time timer 1 to 12) expiration
User function key	User function key (USER1/USER2)
Status	Recording, math, memory/media error, measurement error, communication error

■ Action Types

Item	Explanation
Recording	Starts or stops recording.
Computation	Starts or stops computation (/MT option) or resets the computed values of all math channels.
Flag	Sets a flag to 1 (On) or 0 (Off). (/MT option)
Manual sample	Executes manual sampling.
Alarm ACK	Clears the alarm output.
Event Trigger	Applies a trigger that starts event data recording. You can specify this when the GM is configured to event data.
Message writing	Writes a message. Specify the message number and the message write destination. Set the destination to all groups, or specify a write destination group number. You can execute this while recording is in progress.
Save event data	Saves the event data being recorded to a file in the internal memory. You can specify this when the GM is configured to event data.
Save display data	Saves the display data being recorded to a file in the internal memory. You can specify this when the GM is configured to record display data.
Reset the relative timer	Resets a relative timer. The timer starts immediately.
Load settings	Loads the setting parameter file from the root directory of the SD card and configures the GM accordingly.
Save settings	Saves the current setting parameter to the SD card.
Adjust the time	Sets the clock to the nearest hour.
Relay	Sets the relay output to On or Off.
Internal switch	Sets the internal switch to 1 (On) or 0 (Off).
Load program pattern	Loads all the pattern files (ProgPatYY, YY: 01 to 99) in the specified folder at the root directory of the SD memory card. GM Feature Overview
Load profile trend	Loads the specified files in the "Profile" folder at the root directory of the SD memory card.
Load predictive detection model	Loads the specified files in the "Model" folder at the root directory of the SD memory card.

Possible Combinations of Events and Actions

The combinations that are indicated with ✓ marks in the table below can be used.

Action \ Event	Remote (DI) ³	Relay (DO)	Internal switch	Alarm - IO channel	Alarm - Math channel	Alarm - Communication channel	Any alarm	Health score notification	Timer	Match timer	User function key	Status
Recording	✓	✓	✓	✓	✓	✓	✓	✓	✓	✓	✓	
Recording start/stop1	✓	✓	✓	✓	✓	✓	✓					
Computation	✓	✓	✓	✓	✓	✓	✓	✓	✓	✓	✓	
Computation start/stop1	✓	✓	✓	✓	✓	✓	✓					
Manual sample	✓	✓	✓	✓	✓	✓	✓	✓	✓	✓	✓	
Alarm ACK	✓								✓	✓	✓	
Save display data	✓	✓	✓	✓	✓	✓	✓	✓	✓	✓	✓	
Save event data	✓	✓	✓	✓	✓	✓	✓	✓	✓	✓	✓	
Event trigger	✓	✓	✓	✓	✓	✓	✓		✓	✓	✓	
Message	✓	✓	✓	✓	✓	✓	✓	✓	✓	✓	✓	✓
Reset the relative timer	✓	✓	✓	✓	✓	✓	✓			✓	✓	
Load settings	✓										✓	
Save settings	✓										✓	
Load program pattern	✓										✓	
Adjust the time	✓											
Flag	✓	✓	✓	✓	✓	✓	✓	✓	✓	✓	✓	✓
Flag On/Off ¹	✓	✓	✓	✓	✓	✓	✓					✓
Relay output ²	✓		✓					✓	✓	✓	✓	✓
Relay On/Off ^{1,2}	✓		✓									✓
Internal switch ²	✓	✓						✓	✓	✓	✓	✓
Internal switch On/Off ^{1,3}	✓	✓										✓
Load profile trend	✓										✓	
Load predictive detection model	✓										✓	
Predictive detection section	✓	✓	✓	✓	✓	✓	✓		✓	✓	✓	
HOLD profile trend	✓	✓	✓	✓	✓	✓	✓		✓	✓	✓	
Predictive detection section start/stop ¹	✓	✓	✓	✓	✓	✓	✓					
HOLD profile trend On/Off ¹	✓	✓	✓	✓	✓	✓	✓					

1 When the operation mode is rising/falling edge

2 Action can be set to Relay output, Relay On/Off, Internal switch, or Internal switch On/Off only when the DO channel range type and internal switch type is set to Manual.

3 Only for DI modules installed in the GM main unit whose operation mode is set to Remote.

Event Action Examples

No.	Event Action Description	Event	Action	Other Settings
1	Start and stop recording through remote control.	Remote	Recording start/stop	DI module operation mode: Remote
2	Write a message when an alarm occurs.	Alarm - IO channel	Message	
3	Save event data every day at hour 17.	Match time timer	Save event data	Match time timer setting Timer match condition: 17:00 Timer action: Repeat

3.2.3 Control Event Action Function

The control event action function is used to execute a specified action when certain events occur.

For details, see the Loop Control Function, Program Control Function (/PG Option) User's Manual (IM 04L51B01-31EN).

■ Control Operation

● Loop Control and Common Control

Function	Description
Run all control loops	Starts running all loops when the input changes from off to on.
Stop all control loops	Stops all loops when the input changes from off to on.
Control operation stop/start (specified loop)	Stops the control operation of specified loops when the input changes from off to on. Starts the control operation of specified loops when the input changes from on to off.
Auto/manual switch (specified loop)	Switches the control operation of specified loops to auto when the input changes from off to on. Switches the control operation of specified loops to manual when the input changes from on to off.
Remote/local switch (specified loop)	Switches the control operation of specified loops to remote when the input changes from off to on. Switches the control operation of specified loops to local when the input changes from on to off.
Auto switch (specified loop)	Switches the control operation of specified loops to auto when the input changes from off to on.
Manual switch (specified loop)	Switches the control operation of specified loops to manual when the input changes from off to on.
Cascade switch (specified loop)	Switches the control operation of specified loops to cascade when the input changes from off to on (during cascade control).
Remote switch (specified loop)	Switches the control operation of specified loops to remote when the input changes from off to on.
Local switch (specified loop)	Switches the control operation of specified loops to local when the input changes from off to on.
SP number switch (binary/BCD)	Switches the SP number according to the combination of input ON/OFF states (binary or BCD).

● Program Control

Function	Description
Program RUN/RESET switch	Starts program operation when the input changes from off to on. Stops program operation when the input changes from on to off.
Hold operation	Pauses the operation of program patterns when the input changes from on to off.
Advance operation	Advances the operation of program patterns by one segment when the input changes from on to off.
Start of program operation	Starts program operation when the input changes from off to on.

Continued on the next page

Stop of program operation	Stops program operation when the input changes from off to on.
Hold operation (specified loop, specified program pattern)	Pauses the operation of the specified program pattern of the specified loop when the input changes from on to off.
Advance operation (specified loop, specified program pattern)	Advances the operation of the specified program pattern of the specified loop by one segment when the input changes from on to off.
Start of program operation (specified loop, specified program pattern)	Starts the operation of the specified program pattern of the specified loop when the input changes from on to off.
Stop of program operation (specified loop, specified program pattern)	Stops the operation of the specified program pattern of the specified loop when the input changes from on to off.
Program pattern number switch (binary/BCD selection)	Switches the program pattern number according to the combination of input ON/OFF states (binary or BCD).

■ Notification and Monitoring

Control status monitoring parameters and notifications (events) are output to DO or internal switches (as actions).

Function	Description
Control status (RUN/STOP)	Outputs the control status (RUN status: ON, STOP status: OFF).
Wait end signal (1s, 3s, 5s)	Outputs an ON state signal for 1, 3, or 5 seconds when the program operation wait state ends.
Pattern end signal (1s, 3s, 5s)	Outputs an ON state signal for 1, 3, or 5 seconds when the program operation ends.
PV event status	Outputs an ON state signal while a PV event is occurring during program operation.
Time event status	Outputs an ON state signal while a time event is occurring during program operation.
Wait flag	Outputs an ON state signal while the program operation is waiting.
Hold-on flag	Outputs an ON state signal while the program operation is being held.
Program operation mode monitoring (STOP/RUN)	Outputs the program operation status (RUN: ON, STOP: OFF)
Segment number monitoring (binary/BCD)	Outputs the running segment number in binary or BCD ON/OFF states.
Pattern number monitoring (binary/BCD)	Outputs the running pattern number in binary or BCD ON/OFF states.

* The behavior varies depending on the energize/de-energize state of the contact type.

3.2.4 Batch Function

You can attach batch information to event data files and display data files.
You can manage event data and display data files using batch information.

At the start of recording, batch number, lot number (when in use), and comments (1 to 3) are entered.

Each comment can be entered once during recording.

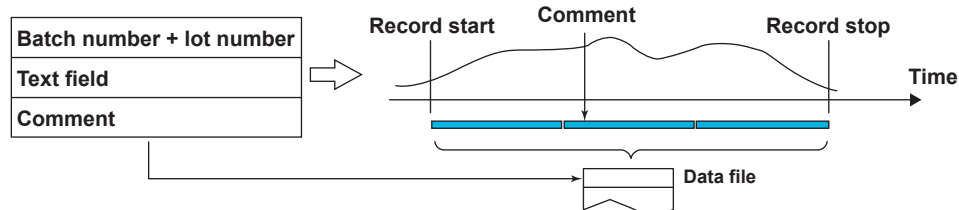

● Batch Information

Item	Explanation	
Batch No.	Up to 32 characters, Aa#1	
Lot No.	Lot numbers can be set to not use, 4 digits, 6 digits, or 8 digits.	
Comments 1 to 3	Up to 50 characters each, Aa#1 You can insert each comment once during recording.	
Textfield	Up to 24 fields can be set.	
	Title	Up to 20 characters, Aa#1
	Label	Up to 30 characters, Aa#1

● Auto Increment Function

Automatically sets the lot number of the next measurement to the current lot number + 1.

● Batch Information Attached to Measurement Data

The following figures show a display example of batch information attached to measurement data using Universal Viewer.

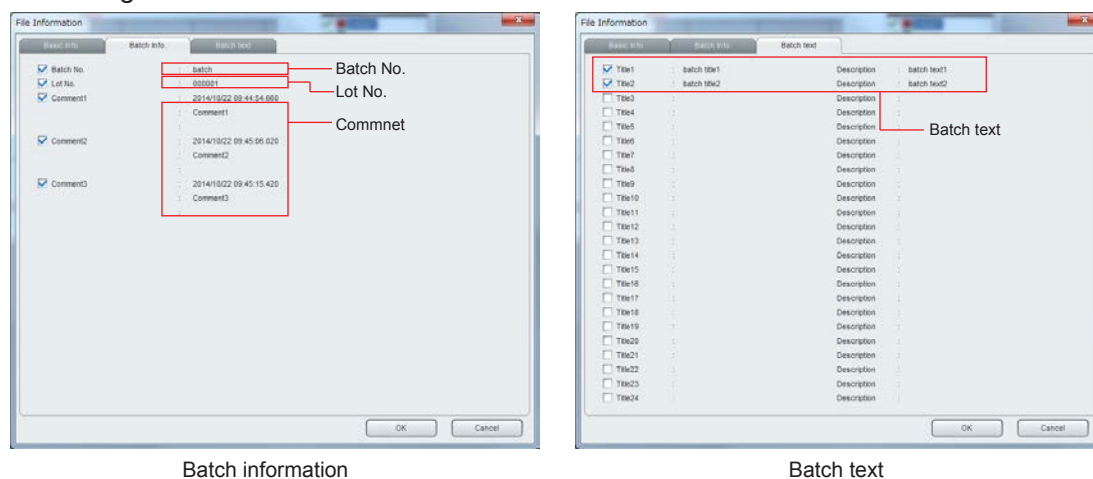

Batch information

Batch text

3.2.5 Math Function (/MT option)

You can define expressions using measured data, computed data, and the like as variables, compute the expressions, and display and save the results. You can set up to 200 (GM10-2) math channels.

■ Computation Types

Classification	Operator	Syntax	Explanation
Basic arithmetic	+	a+b	Determines the sum of a and b
	-	a-b	Determines the difference between a and b
	*	a*b	Determines the product of a and b
	/	a/b	Determines the quotient of a and b
Basic operation	ABS()	ABS(a)	Determines the absolute value of a
	SQR()	SQR(a)	Determines the square root of a
	LOG()	LOG(a)	Determines the common logarithm (log ₁₀) of a
	LN()	LN(a)	Determines the natural logarithm of a
	EXP()	EXP(a)	Determines the exponent of a
	**	a**b	Determines a to the power of b
Relation operator	.GT. (or >)	a.GT.b (or a>b)	The computed result is 1 when a is greater than b. Otherwise, the result is 0.
	.LT. (or <)	a.LT.b (or a<b)	The computed result is 1 when a is less than b. Otherwise, the result is 0.
	.GE. (or >=)	a.GE.b (or a>=b)	The computed result is 1 when a is greater than or equal to b. Otherwise, the result is 0.
	.LE. (or <=)	a.LE.b (or a<=b)	The computed result is 1 when a is less than or equal to b. Otherwise, the result is 0.
	.EQ. (or =)	a.EQ.b (or a=b)	The computed result is 1 when a is equal to b. Otherwise, the result is 0.
	.NE. (or <>)	a.NE.b (or a<>b)	The computed result is 1 when a is not equal to b. Otherwise, the result is 0.
Logical operator	AND	e1ANDe2	If the two data values e1 and e2 are both non-zeros, the computed result is 1. Otherwise, it is 0. (The logical product is determined.)
	OR	e1ORe2	If the two data values e1 and e2 are both zeros, the computed result is 0. Otherwise, it is 1. (The logical sum is determined.)
	XOR	e1XORe2	If the two data values e1 and e2 are zero and non-zero or non-zero and zero, the computed result is 1. Otherwise, it is 0. (The exclusive logical sum is determined.)
	NOT	NOTe1	The result is the inverse of the status of data e1 (zero or non-zero). (The logical negation is determined.)
Statistical operations	TLOG.MAX()	TLOG. MAX(e1)	Determines the maximum value of the specified channel (e1).
	TLOG.MIN()	TLOG.MIN(e1)	Determines the minimum value of the specified channel (e1).
	TLOG.AVE()	TLOG.AVE(e1)	Determines the average value of the specified channel (e1).
	TLOG.SUM()	TLOG. SUM(e1)	Determines the sum of the specified channel (e1).
	TLOG.P-P()	TLOG.P-P(e1)	Determines the maximum - minimum value of the specified channel (e1).
	TLOG.PSUM()	TLOG. PSUM(0001)	Determines the sum of the specified pulse input channel (e1).
	CLOG.MAX()	CLOG.MAX (e1.e2.e4-e6)	Determines the maximum value among the specified group of channels (e1, e2, e4, e5, e6).
CLOG.MIN()	CLOG.MIN (e1.e2.e4-e6)	Determines the minimum value among the specified group of channels (e1, e2, e4, e5, e6).	

Continued on next page

Classification	Operator	Syntax	Explanation
Special operation	CLOG.AVE()	CLOG.AVE (e1.e2.e4-e6)	Determines the average value among the specified group of channels (e1, e2, e4, e5, e6).
	CLOG.SUM()	CLOG.SUM (e1.e2.e4-e6)	Determines the sum among the specified group of channels (e1, e2, e4, e5, e6).
	CLOG.P-P()	CLOG.P-P (e1.e2.e4-e6)	Determines the maximum - minimum value among the specified group of channels (e1, e2, e4, e5, e6).
	PRE()	PRE(e1)	Determines the previous value of e1.
	HOLD()	HOLD(a);b	When a is zero, b is carried out to derive the computed value. Otherwise, the previous computed value is held.
	RESET()	RESET(a);b	When a is zero, b is carried out to derive the computed value. Otherwise, the previous computed value of b is reset, and b is carried out to derive the computed value.
	CARRY()	CARRY(a);b	Only TLOG.SUM can be specified for b. If the computed value X of b is less than a, the computed result is X. If X is greater than or equal to a, the computed result is the excess (X - a).
Conditional expression	[a?b:c]	[a?b:c]	If the value of expression a is true, expression b is executed; otherwise expression c is executed.
Remainder extracting operation	.MOD.	a.MOD.b	Determines the remainder when a is divided by b.
Integer extracting operation	INT()	INT(a)	Determines the maximum integer that does not exceed a
Trigonometric function	SIN()	SIN(a)	Determines the sine value assuming the data of a to be an angle in degrees.
	COS()	COS(a)	Determines the cosine value assuming the data of a to be an angle in degrees.
Bit output	BIT.Bnn(a)		Outputs the value of the specified bit (Bnn) from bit data a (positive integer)
Recording status	REC1	REC1	Set to 1 if recording is in progress and 0 if recording is stopped.

■ Data That Can Be Used in Expressions

Data	Range
I/O channel data	0001 to 6950
Math channel data (/MT)	GM10-1: A001 to A100 GM10-2: A001 to A200
Constant	K001 to K100
Variable constant	W001 to W100
Communication channel data (/MC)	GM10-1: C001 to C300 GM10-2: C001 to C500
Communication channel raw data (/MC)	GM10-1: RC001 to RC300 GM10-2: RC001 to RC500
Internal switch status	S001 to S100
Flag	F01 to F20
Recording status	REC1 to REC12
Integer data	Z001 to Z999

3.2.6 Logic Math Function

Logic math is a function that outputs calculated results as 0 or 1 to relays (DOs) or internal switches. Up to 50 logic math operations can be set.

● Computation Types

Type	Computing Element
Auxiliary operation	+, -
Basic arithmetic	+, -, *, /
Relational operation	.GT., .GE., .LT., .LE., .EQ., .NE., >, >=, <, <=, =, <>
Logical operation	AND, OR, NOT, XOR
Conditional operation	[expression 1 ? expression 2 : expression 3]
Bit operation	BIT.Bnn()

3.2.7 Report Function (/MT option)

The report function can be used to create a variety of report files from the measured data of I/O channels, math channels, and communication channels.

You can set up to 60 report channels. You can set up to five computation types.

You can select whether to save report files separately for each kind of report or two kinds of reports in a single file.

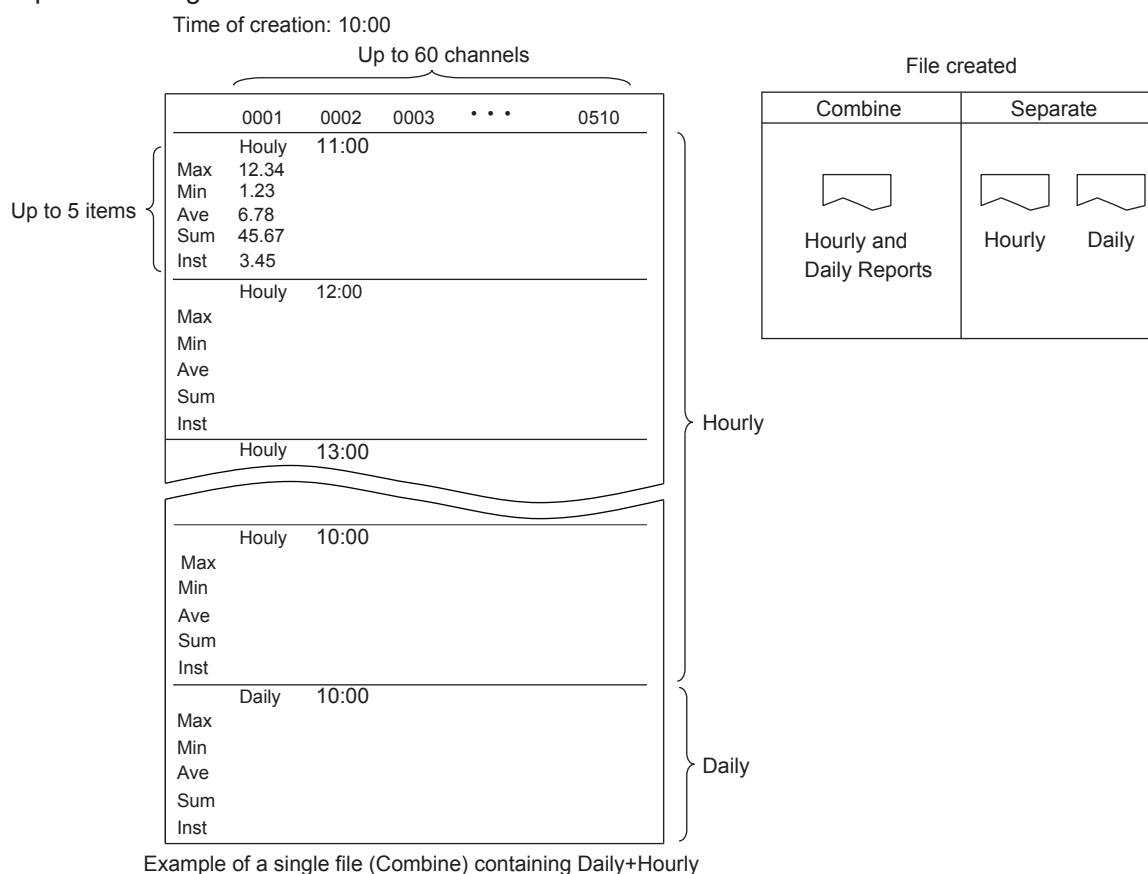

● Report Kind

Item	Explanation
Hourly + Daily	Creates hourly and daily reports. Hourly report: Creates report data every hour on the hour for the previous one hour. Daily report: Creates report data every day at a specified time for the previous one day.
Daily + Weekly	Creates hourly and weekly reports. Weekly report: Creates report data every week at a specified time at a specified day of the week for the previous one week.
Daily + Monthly	Monthly report: Creates report data every month at a specified time at a specified day for the previous one month.
Batch	Creates a report in unit of batches.
Daily custom	Creates daily reports by dividing it at the specified time intervals.

● Computation Types

Item	Explanation
Ave	Outputs average values.
Max	Outputs maximum values.
Min	Outputs minimum values.
Sum	Outputs sum values.
Inst	Outputs instantaneous values.

3.2.8 Report Template Function

You can create report templates and use them to automatically create custom report files. Load a report template file that you have created into the GM internal memory. The GM will automatically create report files using the report template file.

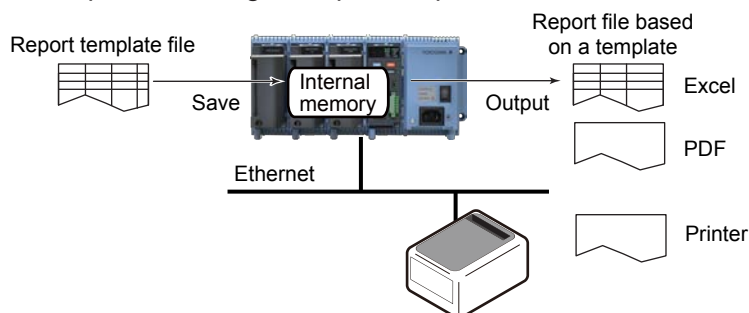

● Files Created by Using Report Template Files

Report File	Template	Explanation
Report files in Excel format	Excel format	A report template for each kind of report file is created. For each kind of report file, a corresponding report template file is used to create the appropriate report files.
Report files in PDF format	Yokogawa proprietary format	
Report output to printer	Yokogawa proprietary format	The report template for PDF reports is used to output data to the printer.

● Creating Report Templates for PDF Report Files and Printer Output

To create a report template, use the editing tool provided by YOKOGAWA to enter keywords and text in the cells of table.

Keywords specify the type of data that will be entered into a cell. Text are output as they are in reports.

You can download creation tool from the following URL.

<http://www.smartdacplus.com/en/>

3.2.9 Security Function

The security function consists of the following functions.

- Login
- User privileges
- Key lock

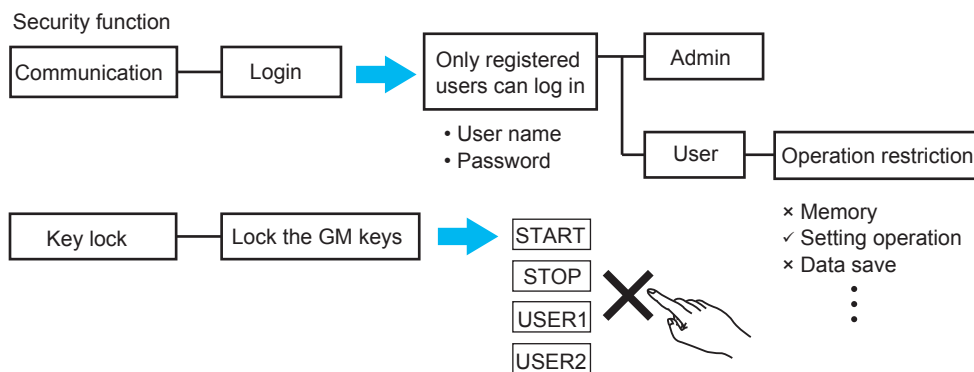

■ Login

Only registered users (administrators and users) can log in to the GM to perform monitoring and operation.

● User Levels

User Level	Explanation
Administrator (Admin)	An administrator can perform all GM operations.
User	Authority of user can be configured to restrict the items that users are allowed to use. A user cannot configure security settings.

● Number of User Registrations

Up to 50 users including administrators (user numbers 1 to 50) can be registered. User number 1 is fixed as an administrator.

● Login Method

Registered users log in to GM by entering their user names and passwords.

■ User Privileges

Limitations can be applied to the operations that a user can perform.

Up to 10 conditions of operation limitations can be set (authority numbers 1 to 10).

For each user, you can set whether to apply user limitations and the conditions to be applied.

Operation limitations

Operation	Explanation
Recording	Restricts record start/stop operation.
Computation	Restricts math start, math stop, and math reset operations.
Data save	Restricts the operations to save display data, save event data, generate event triggers, manual sample, snapshot, reset timer, and reset match time timer.
Message	Restricts message writing operations.
Batch	Restricts batch number writing, lot number writing, comment writing, and text field writing, predictive detection section start, stop, hold..
Alarm ACK	Restricts alarm ACK operations.
Communication	Restricts the operations to start, stop, and test mail; test FTP, get and release network information; test printer output; manually recover Modbus master; and manually recover Modbus client.
Time set	Restricts manual SNTP time adjustment and time setting operations.
Setting operation	Restricts setting operations.
External storage medium	Restricts the operations to save, load, and delete files; manually save data; save alarms; abort saving; create certificate requests; install certificates; and install intermediate certificates; health monitor save..
System operation	Restricts the operations to initialize; reconfigure system; manage, display, and delete certificates; and execute unverified certificates.
Output operation	Restricts internal switch operations and relay operations.

■ Key Lock

The GM (Data Acquisition Module) keys (START, STOP, USER1, USER2) can be locked.



3.2.10 Fail, Status Output

CPU errors (FAIL) and status can be output as relay signals.

You can select which status to output from event action.

To output relay signals, you need a digital output module (GX90YD) or digital input/output module (GX90WD).

■ Status Output Item

Device information		Description	Details
Device status	Recording	A relay signal is output when recording starts.	-----
	Math	A relay signal is output when computation starts.	-----
	User lock out	A relay signal is output when a user lockout occurs.	-----
	Memory/media error	A relay signal is output when an error occurs in the internal memory or external storage medium.	Error in the internal memory. Error in the external storage media.
	Measurement error	A relay signal is output when a measurement error occurs.	Error in the A/D converter. A burnout was detected. This occurs when thermocouple or RTD wires are disconnected or when general signals are outside the specifications. Module error was detected.
	Communication error	A relay signal is output when a communication error occurs.	A communication error occurred in the Modbus master, Modbus client, WT communication (/E2 option), or SLMP communication (/E4 option).
Alarm		A relay signal is output when an alarm occurs. However, alarms that are set not to display their occurrence are not output to the relay.	-----

3.2.11 Timer and Internal Switch Functions

■ Timers

Timers are used in event action and computation (/MT option). There are two types of timers: absolute and relative. You can set up to twelve timers for each type.

● Absolute Timer

The timer expires at the times determined by the reference time and the interval. The reference time is set on the hour (00 to 23).

Absolute timer

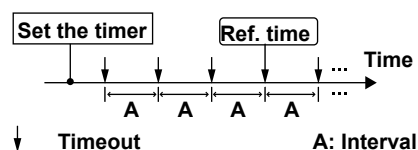

Example: Reference time: 00:00

Interval: 10 minutes

The timer expires at 0 hour, 0 hour 10 min, 0 hour 20 min, . . . 23 hour 40 min, and 23 hour 50 min.

For example, if the timer is set at 9 hour 36 min, the timer expires at 09 hour 40 min, 09 hour 50 min, 10 hour, and so on.

● Relative Timer

The timer is started when the timer is set, and the timer expires every specified interval. In this mode, the timer stops when a power failure occurs.

Relative timer

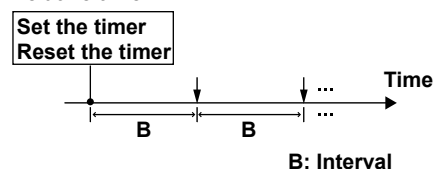

Example: Interval: 15

The timer expires every 15 minutes.

■ Internal Switches

The GM has 100 internal switches (S001 to S100).

You can use them as output destinations for calculation expressions and alarms.

3.2.12 Log Scale Function (/LG option)

A logarithmic voltage that has been converted from a physical value is applied to the GM, and then the GM's Log scale (logarithmic scale) is used to display and record the physical value.

■ Input Type

The GM supports the following three types of input signals.

- **Logarithmic Input**

This is referred to as "Log input." It is an input in which voltages correspond to logarithmic values of physical values.

- **Pseudo Log Input**

This input supports pseudo logs.

A pseudo log signal is a voltage obtained by summing the one's digit of the voltage representing the exponent of the logarithmic data and the decimal digits of the voltage representing the mantissa.

- **Input That Is Linear on a Logarithmic Scale**

This is referred to as "Log linear input." Log linear input is input in which the voltage values correspond to the logarithmic values of physical values at each decade division (e.g., 1×10^2) and in which, within each decade, the voltage values correspond linearly to physical values.

■ Display

The trend display (Web browser) shows waveforms with the Log scale. Digital values are displayed as exponents (e.g., 1.2E+03).

■ Alarms

- **Alarm Values**

Alarm values can be set in the range corresponding to -5% to 105% of the span width on the LOG scale. The mantissa range is 1.00 to 9.99 or 1.0 to 9.9 (depending on the decimal place setting).

- **Alarm Types**

You can set the following alarm types.

H: High limit, L: Low limit, T: Delay high limit, t: Delay low limit

■ Log Input (Nonlinear Log Input) Example

To support the nonlinear output of vacuum gauges, use the calibration correction function to correct the GM input values with linear approximation.

Conceptual diagram

The pressure scale is mapped to an input scale that has been multiplied by a constant number to derive the output scale.

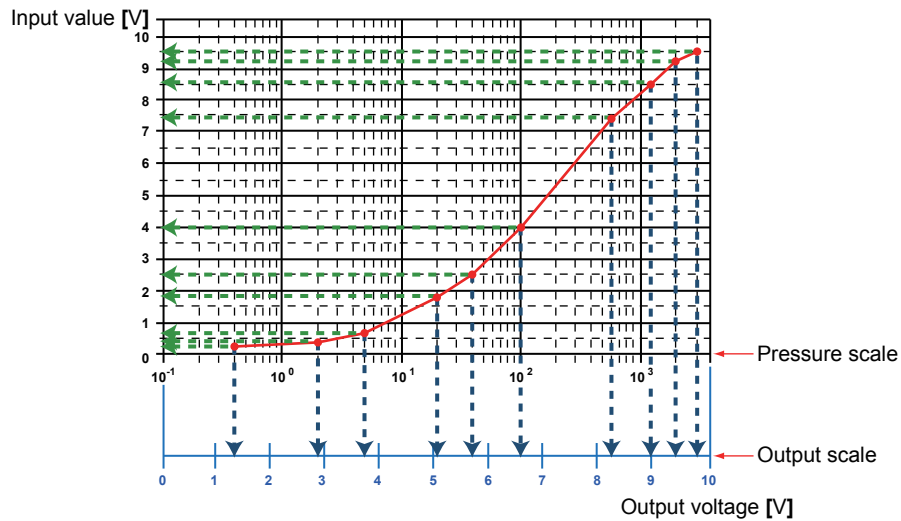

3.3 Communication and Network Functions

3.3.1 DHCP Function

IP parameters can be set automatically using DHCP.

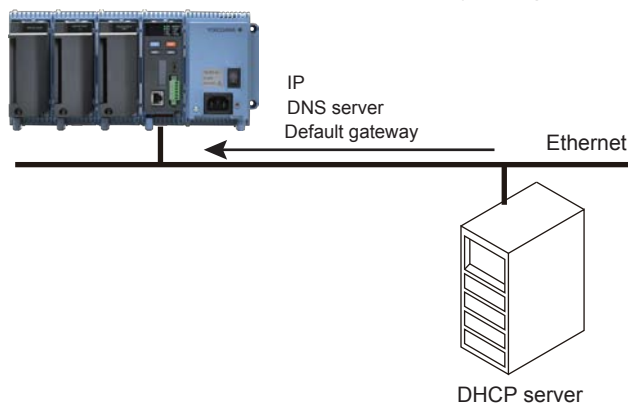

3.3.2 File Transfer Function (FTP)

The GM has FTP server and FTP client file transfer functions.

■ Server

You can use a PC to access the GM via FTP. You can perform operations such as retrieving directory and file lists from the external storage medium (SD card) of the GM and transferring and deleting files. In addition, you can also retrieve the directory or file list and transfer files in the internal memory.

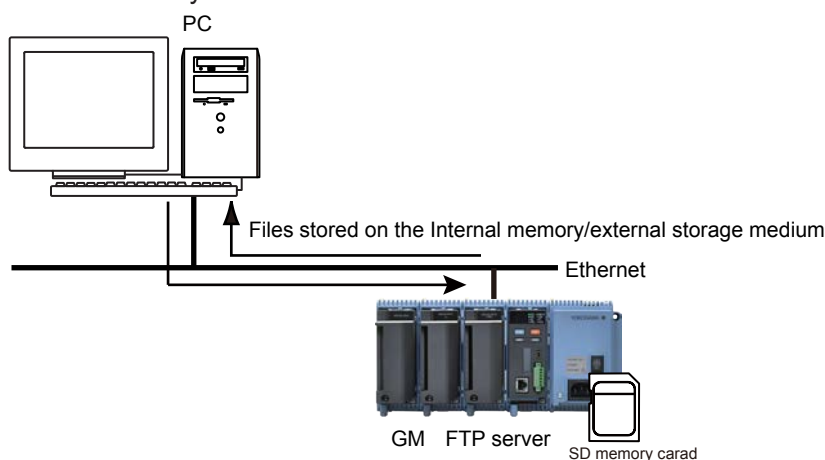

■ Client

The following files that are created in the internal memory of the GM can be automatically transferred using FTP when they are created.

File Type
Event data
Display data
Report data
Alarm summary data
Manual sampled data
Setting file (/AS)
Health monitor

● File Transfer Destination (FTP server)

You can specify two file transfer destinations (FTP servers): primary and secondary. If the primary server is down, the file is transferred to the secondary server.

If the report template function is in use, report files in Excel format and report files in PDF format that are created in the external storage medium of the GM can be automatically transferred when they are created.

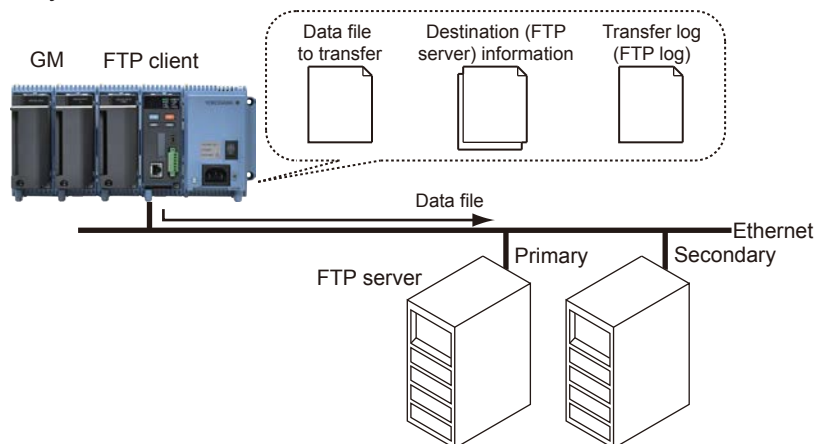

3.3.3 SNTP Function

■ Client

The GM time can be synchronized to the time on an SNTP server (time information server on the network).

The GM can retrieve time information from a specified SNTP server at specified intervals.

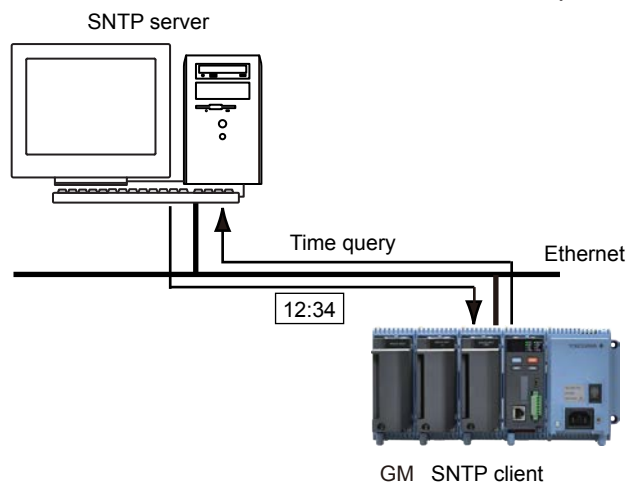

■ Server

The GM can operate as an SNTP server.

When an SNTP client device on the network queries the GM for time information, the GM sends the information.

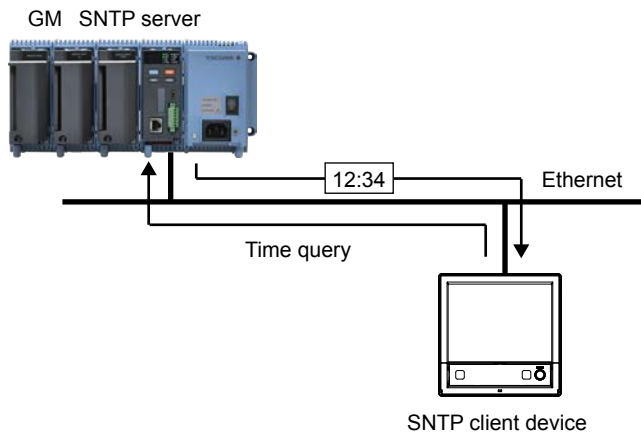

3.3.4 Mail Transfer Function (SMTP)

Mails can be transferred when alarms occur, when reports are created, and so on.

You can set up to two destinations (recipient 1, recipient 2).

You can also set multiple e-mail addresses in a single recipient (space-delimited).

● Mail Transmission Conditions

Classification	Item	Explanation
Alarms	Alarm notification	An e-mail is transmitted when an alarm occurs and when it is released. Instantaneous data can be included. The data that is included is the instantaneous value at the time of the e-mail transmission.
Report	Report notification	An e-mail is transmitted when a report is created.
Periodic	Scheduled notification	An e-mail is transmitted at the specified time. Instantaneous data can be included. The data that is included is the instantaneous value at the scheduled time.
System	Memory full notification	An e-mail is transmitted when the free space on the external storage medium or internal memory is low.
	Power failure notification	An e-mail is transmitted when the GM is powered on or recovers from a power failure.
	System error notification	An e-mail is transmitted when a system error occurs.
	User lockout notification (/AS)	An e-mail is transmitted when a user lockout (user Invalidation) occurs.
	Health score notification	An e-mail a health score notification.

Alarm detection channels

You can set up to 50 channels from I/O channels, math channels, and communication channels.

● Authentication

The following authentication methods are supported.

Authentication
SMTP Authentication
POP before SMTP
APOP

3.3.5 HTTP Function

You can access the GM from a Web browser and monitor measurement data in real time and configure and operate the GM.

For details, see section 3.1.5, "Display (Web browser)."

3.3.6 Communication Channel Function (/MC option)

When data from Modbus devices or PC is recorded on the GM, the acquired data is assigned to communication channels (GM10-1: C001 to C300, GM10-2: C001 to C500).

Data acquired from power meters using WT communication (/E2 option) is also assigned to communication channels.

Alarms can be set on communication channels.

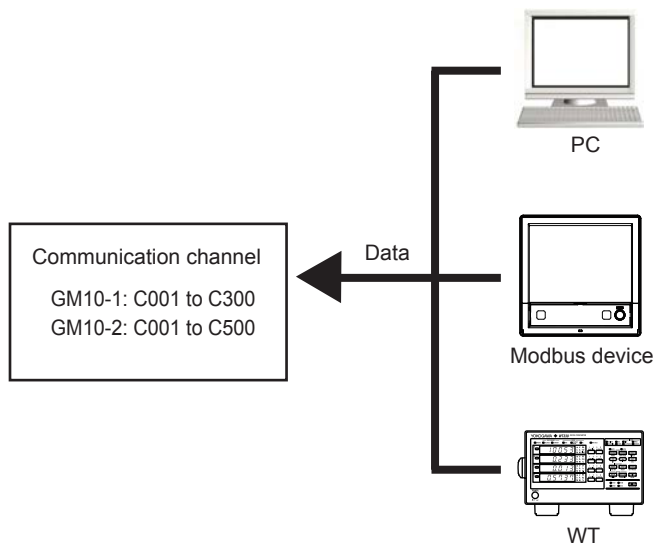

● Watchdog Timer Function

Data may fail to be updated due to Modbus or other communication problems.

The watchdog timer function replaces values with their preset values or last values and when values are not updated within the specified duration (timer).

Data replacement occurs immediately when the timer expires, and the values are held until the next read cycle.

The watchdog timer is also useful for detecting communication interruptions caused by communication errors.

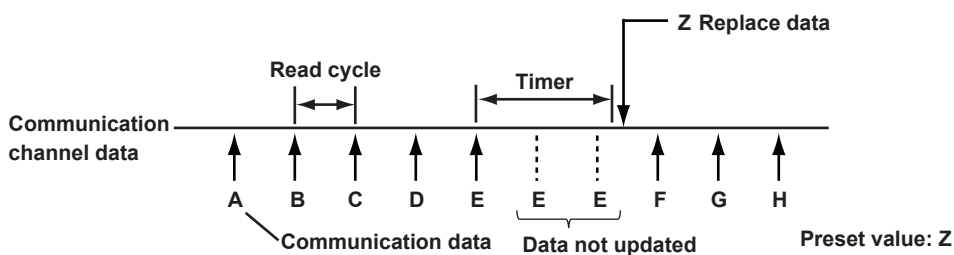

3.3.7 Modbus Function

The Modbus function is used by the GM and external Modbus devices to perform communication and data reading and writing.

The GM can perform the following operations.

Interface	Protocol	Function
Ethernet	Modbus/TCP	Modbus server
		Modbus client (option, /MC)
RS-422/485	Modbus/RTU	Modbus slave
		Modbus master (option, /MC)

■ Modbus Server/Slave Function

The GM can operate as a Modbus server or slave.

Modbus client or master devices can perform the following operations on the GM.

- Read I/O channel and math channel (/MT option) data
- Read communication channel (/MC option) data
- Write data to communication channels
- Start and stop recording, write messages, and perform other operations
- Load the recording start/stop condition, message strings, and other types of data
- Limit the IP addresses that can connect to the GM Modbus server function.

Client devices can transmit commands to the GM to read data from and write data to the GM internal registers. By writing data to the GM internal registers, you can control the GM (such as start recording).

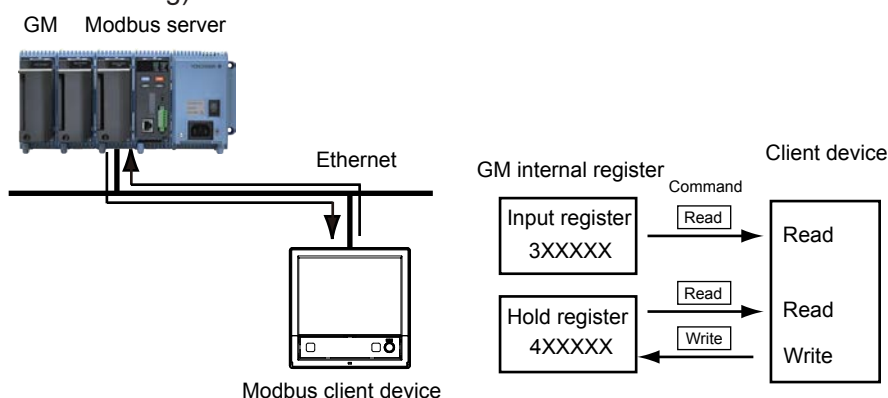

● Maximum Number of Client Connections When Operating as a Modbus Server

Type	Maximum Number of Client Connections
GM10-1	4
GM10-2	4

■ Modbus Client/Master Function

The GM can operate as a Modbus client or master. It can read from and write to the internal registers of Modbus server or slave devices. Read data can be assigned to communication channels (/MC) for processing.

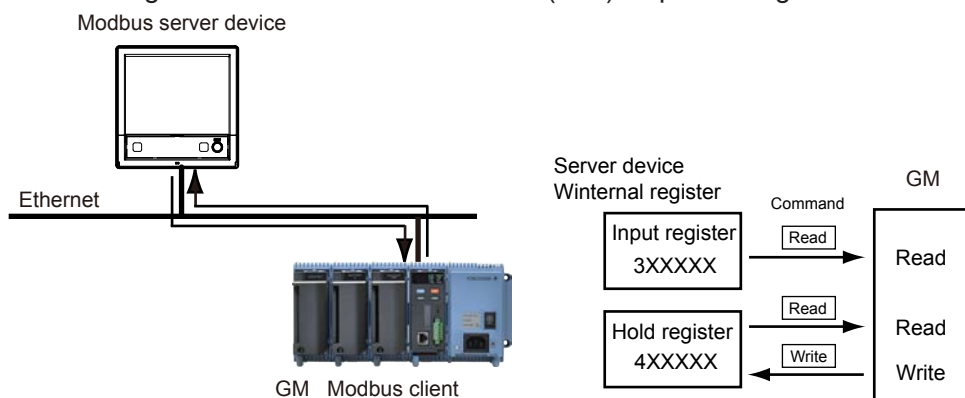

● Number of Commands

Type	Number of Commands
GM10-1	100
GM10-2	200 (Modbus client) 100 (Modbus master)

● Maximum Number of Server Connections When Operating as a Modbus Client

Type	Maximum Number of Server Connections
GM10-1	16
GM10-2	32

● Writable Data

Data Type
I/O channel data
Math channel data (/MT option)
Communication channel data (/MC option)

3.3.8 SSL Communication Function

Communication that sends and receives information encrypted by the SSL protocol is possible. Public key encryption and certificate are used to encrypt communication and secure the connection.

SSL(Secure Sockets Layer)

SSL is a function for encrypting data communication between devices on the Internet and other networks. It ensures safe data transmission such as by preventing spoofing by other devices and data eavesdropping.

■ Supported Servers

HTTP server and FTP server are supported.

● HTTP Server Function

A certificate is saved in the internal memory in advance.

When a PC accesses the GM's Web server, the certificate is sent from the internal memory to the PC. Encrypted data is exchanged.

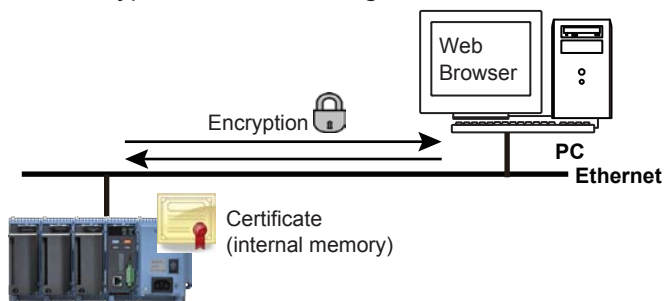

● FTP Server

A certificate is saved in the internal memory in advance.

When a PC accesses the GM's FTP server, the certificate is sent to the PC. Encrypted measurement data is exchanged.

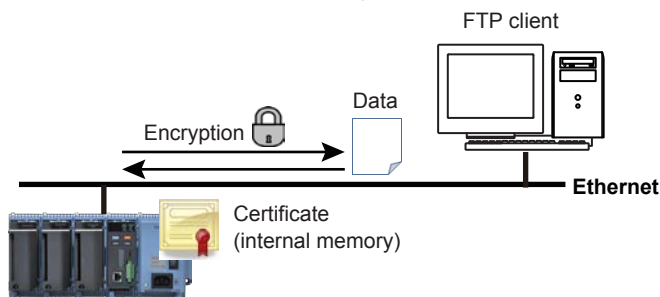

■ Supported Clients

FTP client and SMTP client are supported.

● FTP Client

A trusted certificate is saved in the internal memory in advance.

When an access is made to an FTP server, it compares the certificate received from the server to the one in the internal memory. Encrypted data is sent to the server.

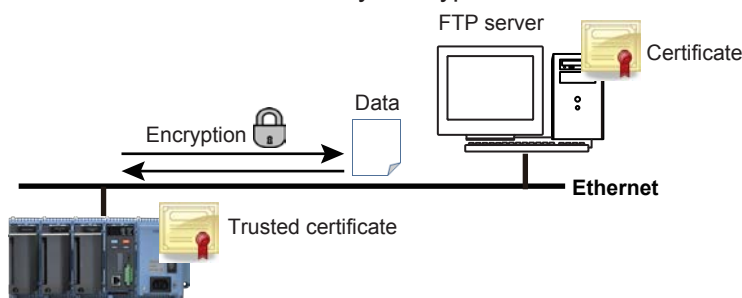

● SMTP Client

A trusted certificate is saved in the internal memory in advance.

When an access is made to an SMTP server, it compares the certificate received from the server to the one in the internal memory. Encrypted e-mail is sent to the server.

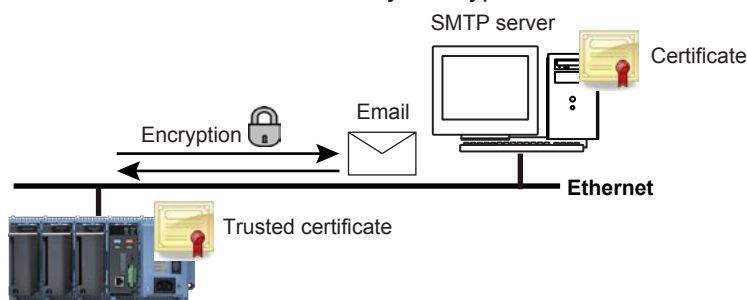

■ Trusted Certificate, Electronic Signature Function

● Trusted Certificate

Trusted certificates (up to 100KB total) can be saved in the internal memory.

Certificates received from servers can be compared to the ones in the internal memory.

● Electronic Signature Function

Electronic signatures can be added to report files created in PDF format using the PDF form creation function. Electronic signatures are applied when reports are created.

● Electronic Signature Certificate

Electronic signature certificates that users create can be saved in the internal memory.

3.3.9 DARWIN Compatible Communication

A portion of the DARWIN's setting and control commands is supported. Measured data, math data, and the like can be output in DARWIN format. You can use an existing program that has been created for DARWIN to communicate with the GM. Ethernet and RS-422/485 are supported.

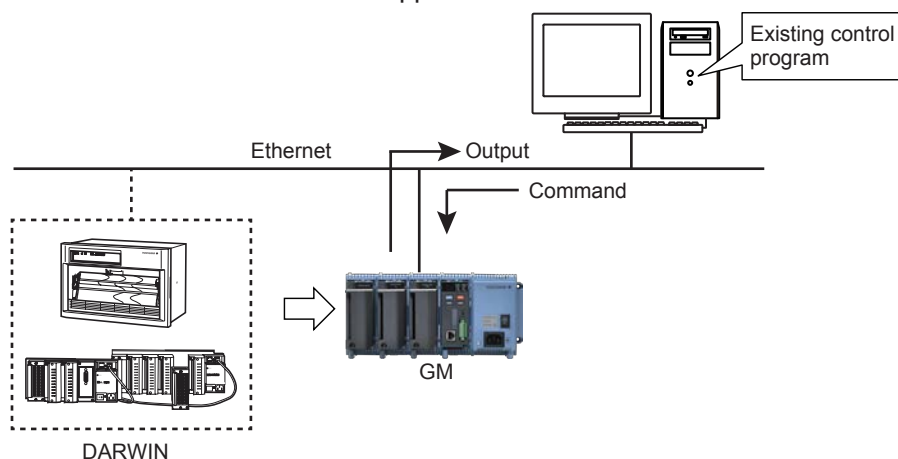

■ Supported Commands

● Instantaneous Data Output Commands

Command	Description
EF	Outputs measured data and math data in binary format.
EL	Outputs unit and decimal point information of a specified channel in ASCII format.
EB	Sets the byte output order.

● ESC+T Command

If a "Esc+T" command is received, time-synchronized measured value and math value are held in the local buffer until the next "Esc+T" command is received.

Command	Description
ESC+T	Prepares to output the data selected with the TS command.

● Setting Commands

Command	Description
SR	Sets the range.
SN	Sets the unit (scale unit).
SA	Sets an alarm.
SC	Sets the chart speed.
SZ	Sets the zone recording.
PT	Sets the analog recording.
SD	Sets the date and time.
SV	Sets moving average.
AO	Assigns a reference channel to the retransmission output channel
CM	Sets math input data (option).

● Commands Applicable to RS-422-A/RS-485 Only

Command	Description
ESC+O	Open Command (address a communication destination)
ESC+C	Close Command (close the addressed state of a device)

• Data Output Request Commands

Command	Parameter	Description
TS	0: Measured data	Selects the talker output data.
	1: Setting parameters	
	2: Unit information	
	5: System configuration information	
	9: Setup mode setting data output	
FM	0: Measured data (ASCII)	Selects the output format of measured/math data.
	1: Math data (binary)	
	2: Math data (ASCII)	
	3: Math channel (binary)	
LF	–	Sets the output channel for the setting data output, unit, and decimal place information.
CF	–	Sets the system configuration data format.
VF	–	Relay status output request
BO	–	Sets the byte output order.
ESC+S	–	Status byte output command

• Control Execution Commands

Command	Description
AR	Resets alarms.
IR	Resets timers.
EX	Starts, stops, resets, clears (option) math.
RS	System reconfiguration.
RC	Clears RAM (initializes operation mode setting parameters).
VD	Turns on and off relays externally.
CF	System configuration data output request (diagnosis).
PS	Starts or stops recording.
MS	Starts message printing.
IM	Sets the interrupt mask.
SM	Sets the auxiliary mask.

• Handling of Commands for Functions Not Available on the GM

If a command or parameter for a function not available on the GM is received, a negative response (E1) is returned.

However, if the command does not constitute a functional problem, a positive response (E0) is returned without performing any operation.

Commands That the GM Returns Positive Responses For

Command	Description	Response	Operation
DS	Switches the setting mode.	Positive response	No operation
XE	Confirms setup setting parameters.		
UD	Sets the display mode of the top display.		
ESC+R	Switch from Local Status to Remote Status.		
ESC+L	Switch from Remote Status to Local Status		

Commands That Do Not Affect the Operation (Negative response)

Command	Description	Response	Operation
SX	Sets a math group.	Negative response	No effect
SI	Sets a timer (option).		
SQ	Sets a match time timer (option).		
SL	Sets event/action (option).		
SO	Sets a calculation expression (option).		
SK	Sets a calculation constant (option).		
AO	Assigns a transmission channel.		
YO	Sets the time constant for transmission output.		
ET	Sets a timeout.		

3.3.10 EtherNet/IP Function (/E1 option)

■ EtherNet/IP Overview

EtherNet/IP is a protocol that extends Common Industrial Protocol (CIP) to Ethernet. The use of Ethernet enables high-speed and periodic exchange of massive control and monitoring data between control devices placed at dispersed locations.

Devices that support EtherNet/IP are available from many vendors. Among them, Rockwell Automation's Programmable Logic Controller (PLC) and Remote I/O of the Allen-Bradley brand are widely used. Yokogawa's GM, equipped with the EtherNet/IP server function, supports communications with these PLCs.

■ GM Functions

The GM provides the following functions:

- Participate in an EtherNet/IP network as an Adapter (Server).
- Communicate with new and old Allen-Bradley PLCs such as MicroLogix, CompactLogix, ControlLogix, SLC 500, PLC-5, and PLC-2.
- Support both Explicit and I/O messages.

Explicit Message	Target PLC	Command name
Explicit Message	PLC-2	PLC2 Unprotected Read/Write
	PLC-5	PLC5 Word Range Read/Write
		PLC5 Typed Read/Write
	SLC	SLC Typed Read/Write

- PLCs can access internal data of the GM.

Data	Access
Input/Output channel data	Read
Computation channel ¹ data	Read
Communication channel ² data(Read/Write)	Read/write

1 Option (/MT)

2 Option (/MC)

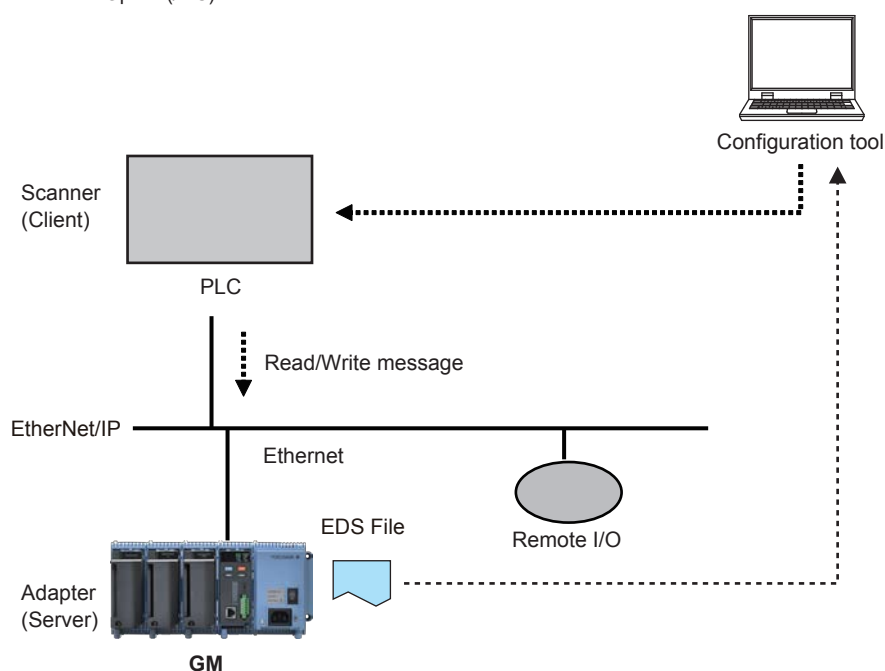

3.3.11 WT Communication Function (/E2 option)

The WT communication function is used by the GM to acquire values measured and computed on WT power meters and analyzers made by Yokogawa Meters & Instruments Corporation. The values are acquired in digital form over Ethernet.

The acquired data can be assigned to communication channels (/MC option) and displayed and recorded simultaneously with the measured temperature or other data of the GM.

Previously, the GM measured the D/A conversion output of power meters (measured values converted into analog signals). This was compromising the high-precision data that the power meters were measuring.

The WT communication function maintains high precision by acquiring the digital values.

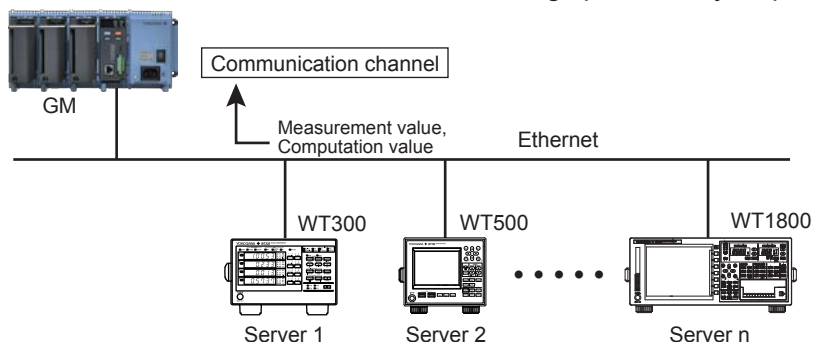

Connectable Models and Options

Maker	Models	Option	Description
Yokogawa Meter & Instrument	WT300/WT330	/G5	Harmonics Measurement
		/G5	Harmonics Measurement
	WT500	/DT	Delta computation
		/G5	Harmonic Measurement
	WT1800	/G6	Simultaneous Dual Harmonic Measurement
		/DT	Delta Computation
		/MTR	Motor Evaluation Function
		/AUX	Auxiliary Sensor Inputs

General Specifications

Item	Specifications
Maximum number of simultaneous connections	16
Data acquisition interval	500 ms/1s/2s/5s/10s/20s/30s
Number of acquisition data assignments	300 (assigned to communication channels)

Other Functions

Exponential scaling

Exponential scaling can be applied to data acquired from a WT.

For example, if the measured value of the WT is 123.45 kW, the data can be scaled by 10^{-3} to derive data in unit of kW.

Watchdog timer

The watchdog timer can be used to detect communication interruptions caused by communication errors.

For details on the watchdog timer function, see section 3.3.6, "Communication Channel Function (/MC option)."

Status output

Notification can be sent through relay output when there is a WT communication error.

For details on status output, see section "3.2.10 Fail, Status Output" on page 3-30.

3.3.12 Bluetooth Function (/C8 option)

Instead of bringing your PC to the site, you can use a tablet to monitor the measurement data (digital display) and configure some of the settings. You must install a dedicated software application in your tablet. For details, visit the YOKOGAWA website.

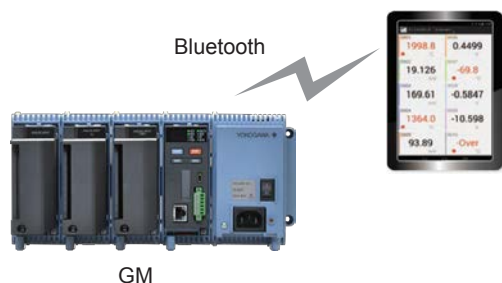

3.3.13 Measurement/Setting Server Function

Dedicated commands can be used to configure the GM, acquire data, and so on.

Supported interfaces

- Ethernet
- USB
- RS-422/485 (/C3)
- Bluetooth (/C8)

3.3.14 Advanced security function (/AS option)

This function makes the GM comply with FDA 21 CFR Part 11 (Electronic Records; Electronic Signatures). It enables the GM to be used in pharmaceutical production and other various applications that require strict security, data management, and electronic signatures. For details, see the Data Acquisition System GM Advanced Security (/AS) User's Manual.

3.3.15 Multi-batch Function (/BT option)

The Multi Batch function allows you to record and save the measured data from multiple batches separately (per batch). You can also apply the Multi Batch function to multiple consecutive processes.

Features

Start and stop recording separately for each batch and create data files for each batch.

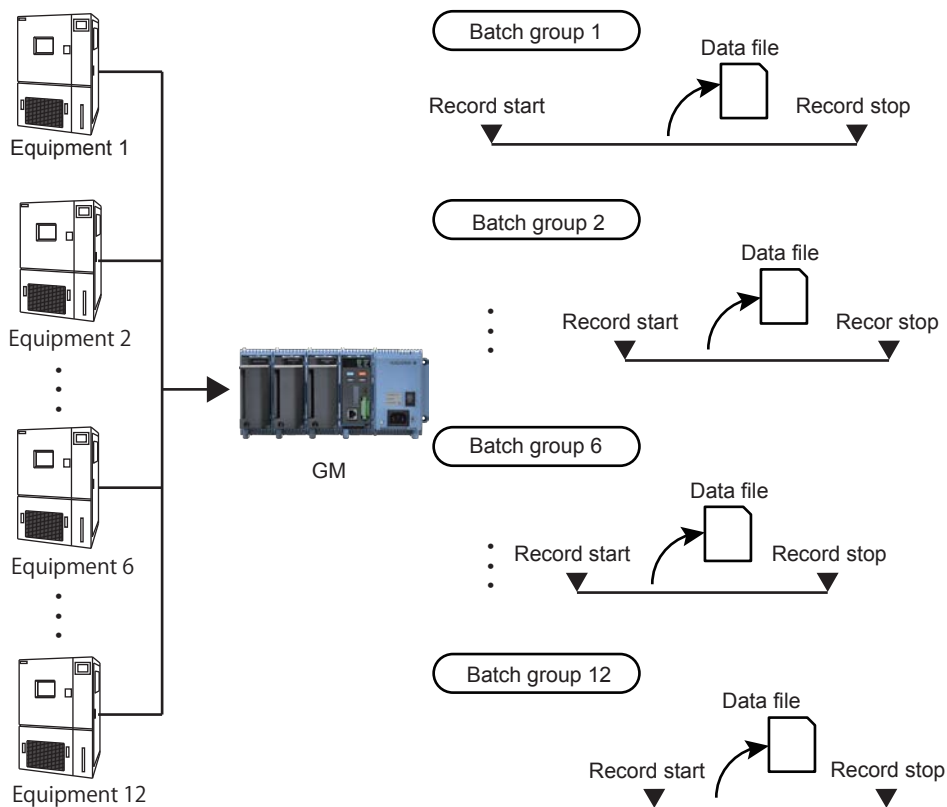

● Main Specifications

Item	Specification
Number of multi batches	GM10-1: 6 max., GM10-2: 12 max.
Batch single operation	Memory start/stop, math reset, message writing
Batch overview operation	Computation start/stop, report start/stop, manual sampling, setup data save/load
Scan interval	500ms, 1 s, 2 s, 5 s (common to all batches)
Data type	Display or event only. Trigger mode not available for event data.
Recording interval	Common to all batches
Data file	Display or event data file created for each batch.
Number of display groups	GM10-1: 6 max. per batch (Number of channels per group: 20) GM10-2: 12 max. per batch (Number of channels per group:20)
Batch single settings	Group, trip line, file header, data file name, text field, batch number, lot number

- For details, see the Multi-Batch Function (/BT) User's Manual.

3.3.16 AEROSPACE HEAT TREATMENT (/AH option)

Supports aerospace heat treatment measurements and NADCAP AMS2750E compliant recording and reporting.

Schedule management for periodically executing calibration correction configuration and the like In correction coefficient mode of calibration.

- Notification Screen**

Manage user-defined schedules for periodical execution.

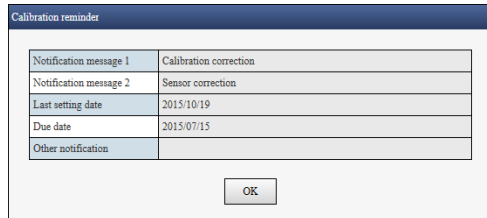

- Operation Example**

When Notification is set to 1 (DayBfr) and Renotification is set to 8h

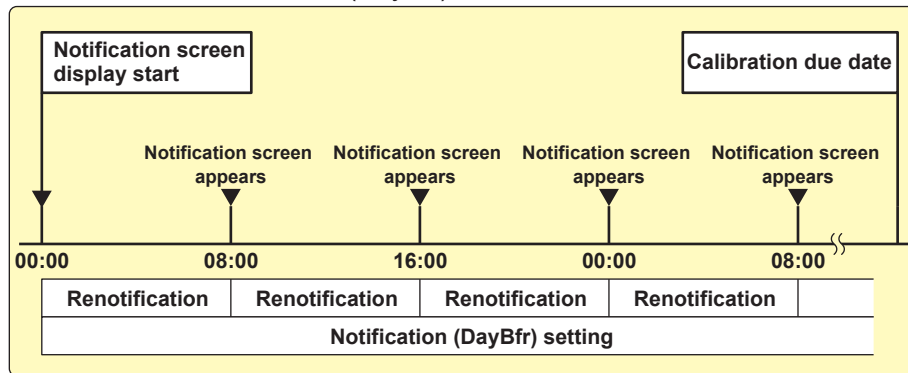

- Reminder Display**

Display the reminder.

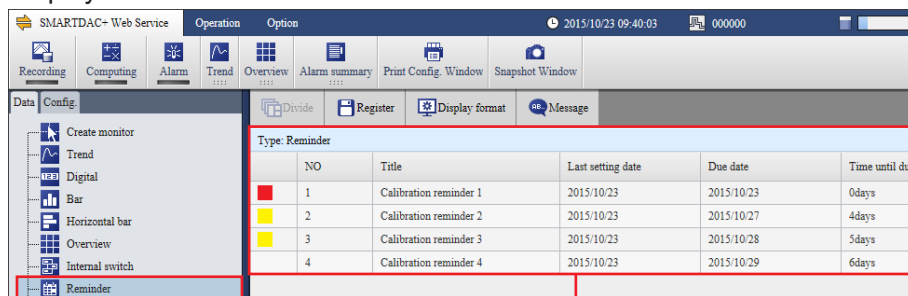

Reminder display

- Calibration correction**

Two biases can be specified: one based on thermocouple and another based on device.

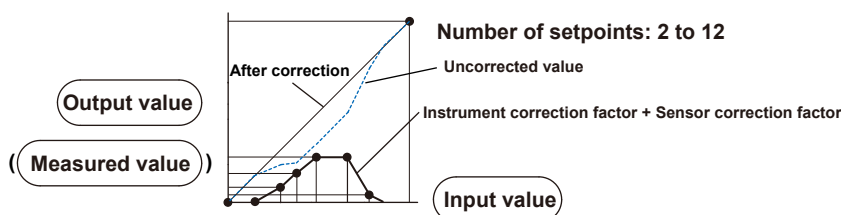

3.3.17 OPC-UA SERVER (/E3)

Data acquired by the GM can be accessed through Ethernet communication from a host system (OPCUA client).

Equipped with an OPC-UA server function. GM measurement data can be retrieved directly from a host system, such as SCADA and MES.

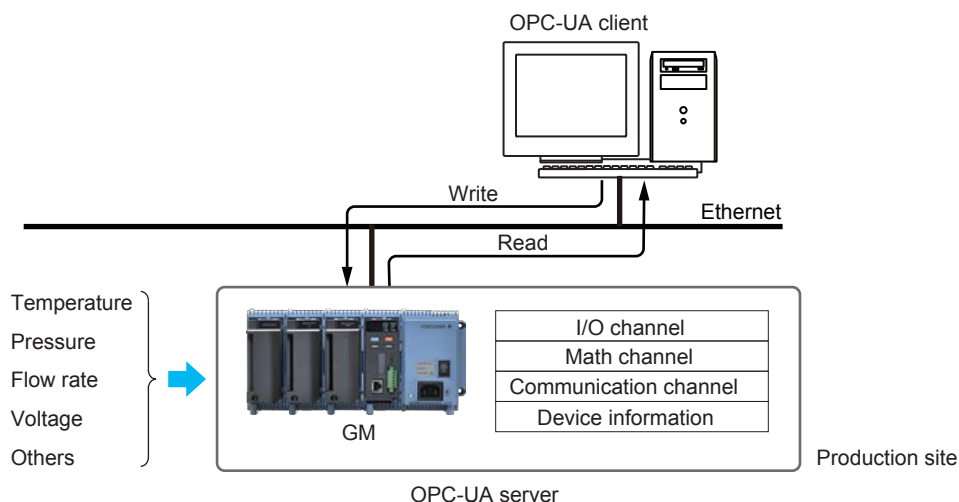

For details, see the OPC-UA Server (/E3) User's Manual.

3.3.18 SLMP COMMUNICATION (Mitsubishi PLC) (/E4)

Protocol function that enables connection from a GM to Mitsubishi Electric PLCs without sequencer programs.

Equipped with a client function for the MC protocol. Connection to Mitsubishi Electric PLCs can be established easily.

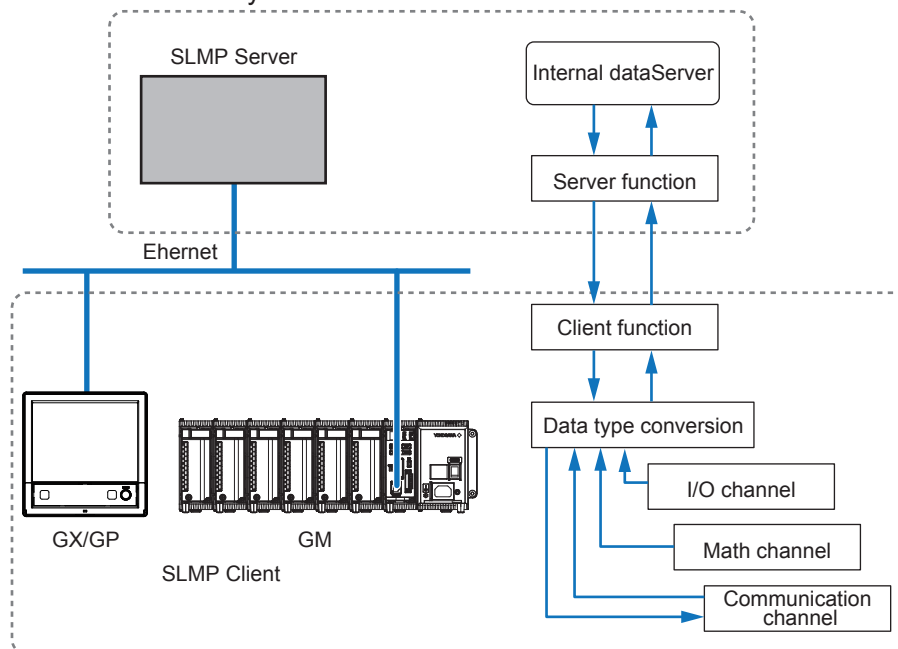

For details, see the SLMP Communication (/E4) User's Manual.

3.3.19 PID Control Function (PID), Program Operation Function (/PG Option)

PID control and program control become possible by installing the PID control module and program control function.

- **Control Function**

A single PID control module can perform PID control on up to two loops. It is equipped with two control inputs (PV inputs), two control outputs, eight digital inputs, and eight digital outputs. In addition to single loop control, cascade control and loop control with PV switching are possible. For the control output, you can select current output or voltage pulse for each loop.

- **Remote Control and Monitoring**

Remote monitoring of sites is possible using the Web application. Control loops can be monitored and controlled from a control group screen, and adjustments can be made from a tuning screen.

- **Program Control Function (/PG option)**

You can perform program control using the program patterns (up to 99 patterns) stored in the GM main unit.

For details, see the Loop Control Function, Program Control Function (/PG Option) User's Manual (IM 04L51B01-31EN).

3.3.20 Equipment/Quality Prediction Function (Release number 5 and later)

Health Monitor Function

By easily creating predictive detection models from past recorded OK/NG data and loading it into GM, you can detect prediction of abnormalities in manufacturing equipment and product quality degradation at an early stage. And because health scores—which show the degree of normal and abnormal data—consider correlations among multiple data to make determinations, they can capture prediction of abnormalities that are difficult for humans to detect.

Profile Function

By creating a profile trend from past recorded data and loading it into GM, this waveform can be used as a threshold for process values. Profile trends are useful in applications where process values change over time. Also, you can see the deviation from the reference waveform on the screen.

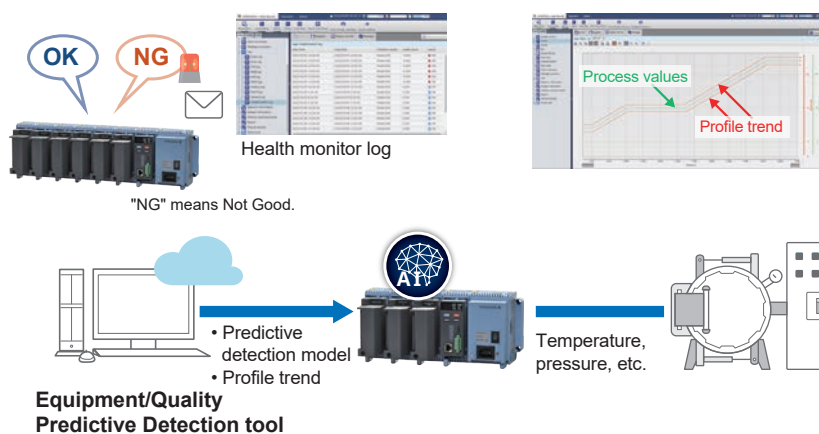

- Predictive detection models and profile trends are created with the equipment/quality predictive detection tool (sold separately: cloud or offline).
 - You cannot use this when the measurement mode is set to high speed or dual interval.
 - If the multi-batch function (/BT option) is enabled, this cannot be used.
 - The communication channel function (/MC option) is required for the profile function.
- * The judgment results of equipment/quality predictive detection functions are reference information and do not guarantee performance or accuracy.

3.3.21 PROFINET Communication (Release number 5 (Version 5.02) and later)

By using the network module (GX90NW-02-PN), it can participate in the PROFINET network as an IO device. IO controllers such as PLCs can access the GM's internal data.

- Supports both cyclic communication and acyclic communication.

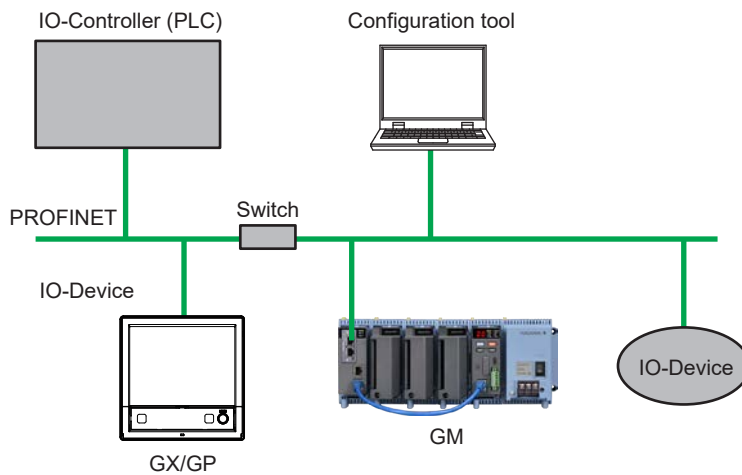

Revision Information

Title : **Data Acquisition System Introduction to the Various Features of the GM**
Manual number : **TI 04L55B01-01EN**

November 2014/1st Edition
Newly published

November 2015/2nd Edition
Add Pulse input module, Multi-batch function, Aerospace heat treatment, OPC-UA server, SLMP communication (Mitsubishi PLC)

June 2017/3rd Edition
Supported Release 4 of the Data Acquisition System GM.

July 2018/4th Edition
Supported Release 4 (version 4.03) of the Data Acquisition System GM.

May 2022/5th Edition
Supported Release 5 (version 5.01) of the Data Acquisition System GM.

September 2022/6th Edition
Supported Release 5 (version 5.02) of the Data Acquisition System GM.

Written by Yokogawa Electric Corporation
Published by Yokogawa Electric Corporation
2-9-32 Nakacho, Musashino-shi, Tokyo 180-8750, JAPAN
