

Data Acquisition System GM First Step Guide



Contents

Introduction	2	Wiring to a GX90XP Pulse Input Module.....	23
Checking the Package Contents	3	Wiring to a GX90YA Analog Output Module.....	24
MODEL and SUFFIX Codes	4	Wiring to a GX90UT PID Control Module.....	24
Standard Accessories	5	Connecting to the RS-422/485 Connector	
Module Notation.....	6	(/C3 option).....	25
GM Overview	6	Connecting to the USB Port	25
GM Configuration.....	6	Connecting to the Ethernet Port	25
Module Version and Notes on Linking.....	6	Wiring the Power Supply	25
Channel Names	8	Turning the Power On and Off.....	27
Operating Procedure.....	10	Connecting GX90EX Expansion Modules	27
Basic Operation.....	12	Bluetooth Connection Procedure (/C8 option).....	28
Names of the GM10 Parts.....	12		
Configuring the GM via Ethernet Communication	12		
Configuring the GM via USB Communication	14		
Starting to Measure and Record.....	14		
Installation.....	15		
Installation Location.....	15		
Installation Procedure.....	15		
Unit External Dimensions (Unit: mm).....	15		
Installing on a Desktop or Floor.....	16		
Mounting on a DIN Rail.....	16		
Mounting on a Wall.....	17		
Wiring.....	18		
Precautions to Be Taken While Wiring	19		
Removing and Attaching a Terminal Cover	20		
Removing and Attaching a Terminal Block	20		
Wiring Procedure.....	20		
Internal dimensions of the M3 screw terminal (unit: mm)	20		
Wiring the Clamp Terminal.....	20		
Wiring to a GX90XA Analog Input Module	21		
Wiring to a GX90XD Digital Input Module.....	22		
Wiring to a GX90YD Digital Output Module.....	23		
Wiring to a GX90WD Digital I/O Module	23		

Introduction

Thank you for purchasing the SMARTDAC+ GM Data Acquisition System (hereafter referred to as the GM). This manual explains the basic operation, installation, and wiring of the GM.

- For details on configuring and operating the GM, see the GM Data Acquisition System User's Manual (IM 04L55B01-01EN) provided in electronic format.
- For details on the settings and operation of the PID control module and program control (/PG option), see the Loop Control Function, Program Control Function (/PG Option) User's Manual (IM 04L51B01-31EN) and the SMARTDAC+ STANDARD Hardware Configurator User's Manual (IM 04L61B01-02EN), provided as electronic manuals.
- For details on installation, wiring, configuration, and PROFINET communication of the network module (GX90NW-02-PN), see the PROFINET Communication User's Manual (IM 04L51B01-22JA) provided as electronic manuals.

This manual covers the following products and I/O modules (GX90 series).

Model	Product name
GM10	Data Acquisition Module for SMARTDAC+ GM
GM90PS	Power Supply Module for SMARTDAC+ GM
GM90MB	Module Base for SMARTDAC+ GM

This manual denotes devices with their product names or model (e.g. GM10).

To ensure correct use, please read this manual and the following manuals thoroughly before beginning operation.

Paper Manuals

Manual Title	Manual No.
Data Acquisition System GM First Step Guide	IM 04L55B01-02EN (this manual)
Precaution on the use of SMARTDAC+	IM 04L51B01-91EN (included)
Regarding the Downloading and Installing for the Software, Manuals and Labels About the Usage of Open Source Software	IM 04L61B01-11EN (included)

Electronic Manuals and General Specifications

You can download these documents from the following web page:

<http://www.smartdacplus.com/manual/en/>

See page 4 in Precaution on the use of SMARTDAC+ (IM 04L51B01-91EN).

General Specifications

Title	General Specifications No.
Data Acquisition System GM	GS 04L55B01-01EN
GX90XA/GX90XD/GX90YD/GX90WD/GX90XP I/O modules	GS 04L53B01-01EN
GX60 I/O Base Unit (Expandable I/O) / GX90EX Expansion Module	GS 04L53B00-01EN

User Registration Request

Thank you for purchasing YOKOGAWA products. Please register to the following Customer Portal Member Site. You can use various services such as confirmation of purchased product information, and download of related materials.

<https://myportal.yokogawa.com/>

Notes

- The contents of this manual are subject to change without prior notice as a result of continuing improvements to the instrument's performance and functions.
- Every effort has been made in the preparation of this manual to ensure the accuracy of its contents. However, should you have any questions or find any errors, please contact your nearest YOKOGAWA dealer.
- Copying or reproducing all or any part of the contents of this manual without YOKOGAWA's permission is strictly prohibited.

Revisions

December 2014	1st Edition	March 2021	9th Edition
August 2015	2nd Edition	May 2022	10th Edition
December 2015	3rd Edition	September 2022	11th Edition
June 2017	4th Edition	October 2023	12th Edition
July 2018	5th Edition		
October 2018	6th Edition		
March 2019	7th Edition		
April 2020	8th Edition		

Trademarks

- SMARTDAC+ is a registered trademark or trademark of Yokogawa Electric Corporation.
- Microsoft, MS, Microsoft Edge and Windows are registered trademarks or trademarks of Microsoft Corporation in the United States and other countries.
- Adobe and Acrobat are registered trademarks or trademarks of Adobe Systems Incorporated.
- The SD logo is a registered trademark of the SD association.
- Bluetooth is a trademark or registered trademark of Bluetooth SIG, Inc.
- Google Chrome is a trademark or registered trademark of Google LLC.
- Company and product names that appear in this manual are registered trademarks or trademarks of their respective holders.
- The company and product names used in this manual are not accompanied by the registered trademark or trademark symbols (® and ™).

QR code

The product may have a QR Code pasted for efficient plant maintenance work and asset information management. It enables confirming the specifications of purchased products and user's manuals. For more details, please refer to the following URL.

<https://www.yokogawa.com/qr-code>

QR Code is a registered trademark of DENSO WAVE INCORPORATED.

Safety Precautions

- Read this manual and "Precaution on the use of SMARTDAC+" (IM04L51B01-91EN) thoroughly and have a clear understanding of the product before operation.
- This manual explains the functions of the product. It does not guarantee that the product will suit a particular purpose of the user.
- Keep "Precaution on the use of SMARTDAC+" and all the related manuals with SMARTDAC+ GM until the end of the use of the product.

- When SMARTDAC+ GM contains GM10 with the optional code of /C8, SMARTDAC+ GM is built in compliance with requirements of R&TTE Directive:
We, Yokogawa Electric Corporation hereby declare that this equipment, model GM Data Acquisition system is in compliance with the essential requirements and other relevant provisions of Directive 1999/5/EC.
The EU declaration of conformity for R&TTE for this product can be found at < <http://www.smartdacplus.com/manual/en/> >
- For details on the advanced security function (/AS option), see the GM User's Manual (IM 04L55B01-01EN) and the Advanced Security Function (/AS) User's Manual (IM 04L55B01-05EN).

Handling Precautions

- Use care when cleaning this instrument, especially its plastic parts. Use a soft dry cloth. Do not use organic solvents, such as benzene or thinner, or other cleansers. They may cause discoloring and deformation.
- Keep electrically charged objects away from the signal terminals. Doing so may damage the GM.
- Do not apply volatile chemicals to the display, panel keys, etc. Do not allow rubber and vinyl products to remain in contact with the GM for long periods of time. Doing so may damage the GM.
- When not in use, make sure to turn off the power switch.
- If there are any symptoms of trouble such as strange odors or smoke coming from the GM, immediately turn off the power switch and the power supply source. Then, contact your nearest YOKOGAWA dealer.

SD Card Handling Precautions

- SD cards are delicate and should be handled with caution.
- Yokogawa provides no warranty for damage to, or loss of data recorded on the SD card, regardless of the cause of such damage or loss. Please always make backup copies of your data.
- Do not store or use the SD card in places with static electricity, near electrically charged objects, or where electrical noise is present. Doing so can result in electric shock or damage.
- Do not disassemble or modify the SD card. Doing so can result in damage.
- Do not physically shock, bend, or pinch the SD card. Doing so can lead to malfunction.
- During reading/writing of data, do not turn OFF the power, apply vibration or shock, or pull out the card. Data can become corrupt or permanently lost.
- Only use Yokogawa SD cards. Operation cannot be guaranteed with other brands of card.
- When inserting the SD card into the instrument, make sure you orient the card correctly (face up or down) and that you insert it securely. If not inserted correctly, the card will not be recognized by the instrument.
- Never touch the SD card with wet hands. Doing so can lead to electric shock or malfunction.
- Never use the SD card if it is dusty or dirty. Doing so can lead to electric shock or malfunction.

- The SD card comes formatted.
SD cards must be formatted according to the standard established by the SD Association (<https://www.sdcard.org/home>). If using a PC to perform the formatting, use the SD card formatter software available from the above SD Association. The GM does not have a format function.
- You can use SD/SDHC cards (up to 32 GB) on the GM.

SD Card Specifications and Characteristics

Electrical specifications	Operating voltage: 2.7 V to 3.6 V
Operating temperature/humidity	-25 to 85°C/20 to 85%RH (no condensation)
Storage temperature/humidity	-40 to 85°C/5 to 95%RH (no condensation)

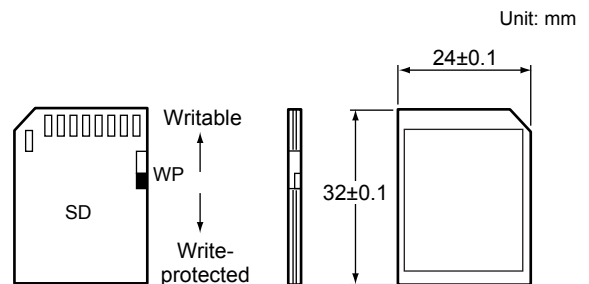

Checking the Package Contents

After receiving the product and opening the package, check the items described below. If the wrong items have been delivered, if items are missing, or if there is a problem with the appearance of the items, contact your nearest YOKOGAWA dealer.

Check that the product that you received is what you ordered by referring to the model name and suffix code given on the nameplate on the GM.

No. (Instrument number)

When contacting the dealer from which you purchased the instrument, please give them the instrument number. The number is inscribed on the nameplate.

MODEL and SUFFIX Codes

GM10

Model	Suffix Code	Optional Code	Description
GM10			Data Acquisition Module for SMARTDAC+ GM
Type	-1		Standard (max. no. of measurement ch: 100)
	-2		Large Memory (max. no. of measurement ch: 500)
Area		E	General
-		0	Always 0
Optional features	/AH		Aerospace heat treatment
	/AS		Advanced security function ⁸
	/BT		Multi-batch function ⁹
	/C3		RS-422/485
	/C8		Bluetooth ¹
	/E1		EtherNet/IP communication (PLC communication protocol) ³
	/E2		WT communication ²
	/E3		OPC-UA sever
	/E4		SLMP communication (Mitsubishi PLC) ⁴
	/LG		LOG scale
/MC		Communication channel function ^{5 12}	
/MT		Mathematical function (with report function) ^{6 7}	
/PG		Program control ¹⁰	
/WH		Integration bar graph function ¹¹	

- Regions in which Bluetooth can be used are restricted by the Radio Waves Act of each country. For details, contact the appropriate authority.
- If you specify WT communication, you must also specify the communication channel function (/MC option).
- If you want to write from a PLC to the GM via EtherNet/IP communication, a communication channel (/MC) is also required.
- If you specify SLMP communication, you must also specify the communication channel function (/MC option).
- If you want to load data from other devices into the GM using Modbus client, a communication channel (/MC) is required.
- If you want to use the GX90XD or GX90WD pulse input, the /MT option (computation) is required.
- If you want to perform pulse integration on GX90XP pulse input modules, the /MT option (computation) is required.
- When the advanced security function is set to ON, the scan interval is set to 100 ms or longer. In addition, the dual interval function and PID modules cannot be used.
- When the multi-batch function is set to ON, the scan interval is set to 500 ms or longer. In addition, the dual interval function cannot be used.
- A PID control module is required to use the program control function.
- If you specify /WH option, you must also specify the communication channel function (/MC option) and the mathematical function (/MT option).
- A communication channel (/MC) is required to use the profile function.

GM90PS

Model	Suffix Code	Optional Code	Description
GM90PS			Power Supply Module for SMARTDAC+ GM
Type	-1		Always -1
Area		N	General
Supply voltage	1		100-240V AC
	2		12-28 V DC ¹
Power supply connection	D		Power inlet with UL/CSA cable
	F		Power inlet with VDE cable
	H		Power inlet with GB cable
	N		Power inlet with NBR cable
	Q		Power inlet with BS cable
	R		Power inlet with AS cable
	W		Screw terminal (without cable)
-		0	Always 0
Optional features		/WH	For Integration bar graph function ²

- Only W (Screw terminal (M4)) is available for the power supply connection.
- When using with GM10 (/WH option), it is necessary to specify the /WH option (for integrated bar graph function) for GM90PS.

GM90MB

Model	Suffix Code	Description
GM90MB		Module Base for SMARTDAC+ GM
Type	-01	Always -01
Language		N General
-		0 Always 0

GX90EX

Model	Suffix Code	Description
GX90EX		I/O Expansion Module
Ports	-02	2 ports
Type	-TP1	Twisted pair cable
-		N Always N
Area		-N General

GX90NW

Model	Suffix Code	Description
GX90NW		Network Module
Ports	-02	2 ports
Type	-PN	PROFINET
-		N Always N
Terminal type		-R RJ-45 connector
Area		-N General

I/O module

GX90XA

Model	Suffix Code	Description
GX90XA		Analog Input Module
Channels	-04	4 channels (Type "-H0" only)
	-06	6 channels (Type "-R1" only)
	-10	10 channels
Type	-C1	Current, scanner type (isolated between channels)
	-L1	DCV/TC/DI (400 VAC, 1 min), Scanner type (isolated between channels)
	-U2	Universal, Solid state relay scanner type (3-wire RTD b-terminal common)
	-T1	DCV/TC/DI, Electromagnetic relay scanner type (isolated between channels)
	-H0	High-speed universal, individual A/D (isolation between channels)
	-R1	4-wire RTD/resistance, solid state relay scanner type (isolated between channels)
	-V1	DCV/TC/DI, high withstand voltage scanner type (isolated between channels)
-		N Always N
Terminal type		-3 Screw terminal (M3)
		-C Clamp terminal
Area		N General

GX90XD

Model	Suffix Code	Description
GX90XD		Digital Input Module
Channels	-16	16 channels
Type	-11	Open collector/voltage-free, contact (shared common), Rated 5 VDC
-		N Always N
Terminal type		-3 Screw terminal (M3)
		-C Clamp terminal
Area		N General

GX90YD

Model	Suffix Code	Description
GX90YD		Digital Output Module
Channels	-06	6 channels
Type	-11	Relay, SPDT(NO-C-NC)
-		N Always N
Terminal type		-3 Screw terminal (M3)
Area		N General

GX90WD

Model	Suffix Code	Description
GX90WD		Digital Input/Output Module *
Channels	-0806	Input 8 channels, Output 6 channels
Type	-01	Open collector/voltage-free, contact (shared common), Rated 5 VDC Relay, SPDT(NO-C-NC)
-	N	Always N
Terminal type	-3	Screw terminal (M3)
Area	N	General

* Optional code /MT (MATH) required if using the pulse input.

GX90XP

Model	Suffix Code	Description
GX90XP		Pulse Input Module *
Channels	-10	10 channels
Type	-11	DC voltage/open collector/non-voltage contact (shared common), rated 5 VDC
-	N	Always N
Terminal type	-3	Screw terminal (M3)
	-C	Clamp terminal
Area	N	General

* When the GM10 has the /MT option, GX90XP can receive pulse integration.

GX90YA

Model	Suffix Code	Description
GX90YA		Analog output Module
Channels	-04	4 channels
Type	-C1	Current output (isolated between channels)
-	N	Always N
Terminal type	-3	Screw terminal (M3)
	-C	Clamp terminal
Area	N	General

GX90UT

Model	Suffix Code	Description
GX90UT		PID Control Module
Number of loops	-02	2 loops
Function	-11	DI 8 points, DO 8 points
-	N	Always N
Terminal type	-3	Screw terminal (M3)
Area	N	General

Customized Product

For customized product, the product is identified by the option code of /S# (where '#' is a number). Contact your supplier in case your instrument has option /S#, and you are not in the possession of IM [Model code]--S# (where [Model code] means, for example, GX90XA).

Standard Accessories

The instrument is shipped with the following accessories. Make sure that all accessories are present and undamaged.

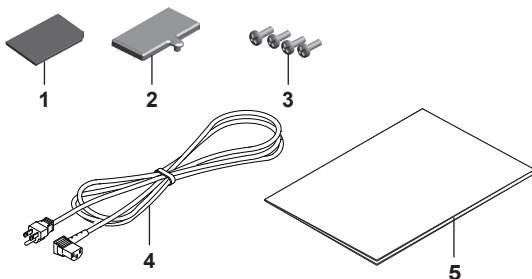

No.	Name	Part Number/Model	Qty.	Notes
1	SD card	773001	1	1 GB (included with the GM10)
2	Connector cover	B8740GN	1	Included with the GM90PS
3	Screws	Y9310LB	4	M3 screws for linking modules (included) ¹
4	Power cord ²	A1006WD	1	D: Power cord UL, CSA st'd
		A1009WD	1	F: Power cord VDE st'd
		A1024WD	1	R: Power cord AS st'd
		A1054WD	1	Q: Power cord BS st'd
		A1064WD	1	H: Power cord GB st'd
		A1088WD	1	N: Power cord NBR st'd
5	Manual	IM 04L55B01-02EN	1	This manual.
		IM 04L51B01-91EN	1	See page 2 of this manual.
		IM 04L61B01-11EN	1	

¹ Four screws included with GM90PS or GM90MB

² When the suffix code of the power supply connection is not W

Optional Accessories (Sold separately)

Name	Part Number/Model	Minimum Qty	Notes
SD card	773001	1	1GB
Shunt resistor (for M3 screw terminal)	415940	1	250Ω±0.1%
	415941	1	100Ω±0.1%
	415942	1	10Ω±0.1%
Shunt resistor (for clamp terminal)	438920	1	250Ω±0.1%
	438921	1	100Ω±0.1%
	438922	1	10Ω±0.1%

GM10 Style Number, Release Number, and Firmware Version Number

Style number: The GM hardware ID number. This number is written on the nameplate (H column). For hardware style, refer GM90PS.

Release number: The GM firmware ID number. This number is written on the nameplate (S column). This number matches with the integer part of the firmware version number. For firmware style, refer GM10.

Example: If the firmware version number is 1.01, the release number is 1.

Firmware version number:

You can check this number on the system information screen of the GM. For the procedure, see the User's Manual (IM 04L55B01-01EN).

Conventions Used in This Manual

- This manual covers information regarding GMs whose display language is English.
- For details on the language setting, see the SMARTDAC+ GM Data Acquisition System User's Manual (IM04L55B01-01EN).

Unit

K: Denotes 1024. Example: 768K (file size)

k: Denotes 1000.

The notes and cautions in this manual are indicated using the following symbols.



Improper handling or use can lead to injury to the user or damage to the instrument. This symbol appears on the instrument to indicate that the user must refer to the user's manual for special instructions. The same symbol appears in the corresponding place in the user's manual to identify those instructions. In the manual, the symbol is used in conjunction with the word "WARNING" or "CAUTION."

WARNING

Calls attention to actions or conditions that could cause serious or fatal injury to the user, and precautions that can be taken to prevent such occurrences.

CAUTION

Calls attention to actions or conditions that could cause light injury to the user or cause damage to the instrument or user's data, and precautions that can be taken to prevent such occurrences.

Note

Calls attention to information that is important for the proper operation of the instrument.

Module Notation

When necessary, the following notations are used to distinguish the GX90XA analog input modules by type.

Type suffix code	Notations
-C1	DC current (mA) input
-L1	Low withstand voltage relay
-U2	Universal
-T1	electromagnetic relay
-H0	High-speed universal or High-speed AI
-R1	4-wire RTD/resistance
-V1	High withstand voltage

GM Overview

The GM Data Acquisition System is a data logger that excels in versatility and expandability. The GM10 contains memory for data acquisition and also supports SD cards for external storage.

The system consists of a Data Acquisition Module (GM10), Power Supply Module (GM90PS), and Module Base (GM90MB), which houses various modules.

GM can operate with SMARTDAC+ series modules.

GM Configuration

The GM configures a system with a combination of various modules.

The unit that includes the GM10 is called the *main unit*. A unit connected to the main unit via a GX90EX expansion module is called a *sub unit*. Modules in a unit can be connected by installing a GM90MB.

Main Unit (single unit system)

A unit consisting of a GM10 and a GM90PS. Up to 10 I/O modules can be connected to a unit.



Main Unit (multi unit system)

A unit consisting of a GM10, a GM90PS and a GX90EX.

Up to six I/O modules can be connected to a unit. Up to six sub units can be connected via the GX90EX.



Sub Unit (multi unit system)

A unit consisting of a GM90PS and a GX90EX. Up to six I/O modules can be connected to a unit. The main unit and sub units are connected using LAN cables. The maximum connection distance between two units is 100 m.



Module Version and Notes on Linking

Module Version

The following table lists the module firmware versions that can be used with the GM. For modules not listed in the following table, R1.01.01 and later can be used.

Model	Type	Firmware version
GX90XA	-C1	R1.04.01 or later
	-L1	R1.04.01 or later
	-U2	R1.04.01 or later
	-T1	R1.04.01 or later
GX90XD		R1.04.01 or later
GX90WD		R1.04.01 or later
GX90YD		R1.04.01 or later
GX90EX		R1.02.01 or later

Limit to the number of modules per unit

The system will not operate if it exceeds the following limits.

- When GX90XA-10-T1 is included

Single unit system	8
Multi unit system: main unit	No limi

- When GX90XA-04-H0 is included

Single unit system	8
Multi unit system: main unit	No limi

- When GX90XA-04-H0 and GX90YA are included

Single unit system	7
Multi unit system: main unit	No limi

- When GX90UT is included

Single unit system	5
Multi unit system: main unit	5

Limit to the Number of Sub Units

- Up to six units can be connected.
- Connection is not possible if the measurement mode is set to High speed.

Limit on Modules

- Up to 10 modules consisting of GX90YD, GX90WD, and GX90UT can be connected to the system.
- One GX90WD module can be connected to each unit.
- Two GX90YA modules can be connected to the main unit and to the sub unit.
- Up to 10 GX90YA modules can be connected to a GM10-1 system and up to 12 to a GM10-2 system.
- If the measurement mode is High speed, a GX90XD or GX90WD module can be connected to the system.
- If the measurement mode is High speed, only GX90XA-04-H0 (high-speed AI), GX90XD (DI), GX90WD (DIO), and GX90NW are detected. DI and DIO are fixed to remote mode. Measurement and recording are not possible.
- If the measurement mode is Dual interval, GX90UT is not detected.
- Up to 3 GX90UT modules can be connected to a GM10-1 system and up to 10 to a GM10-2 system.

Restrictions when using the network module GX90NW (method: PROFINET)

- The GX90NW can only be used with the main unit (single unit). The available connection position is the first left side toward the front of the main unit.
- The GX90NW cannot be used with the expansion module (GX90EX) at the same time.
- When GX90XA or GX90YA is included, up to 6 modules can be connected including GX90NW.

Notes on Module Installation

- If you want to use reference junction compensation on a thermocouple input of a GX90XA-10-U2, GX90XA-10-L1, GX90XA-10-T1, GX90XA-04-H0 or GX90XA-10-V1, do not connect the following module to the right of the GX90XA module as seen from the front. Doing so may cause the reference junction compensation accuracy to deviate from the guaranteed range. GX90XA-10-C1 (for mA), GX90XA-04-H0 (high-speed AI), GX90YA, GX90WD, GX90UT
- If the maximum number of I/O channels are assigned and the last channel is assigned to an intermediate channel of a connected I/O module, that module and subsequent modules will not be identified.

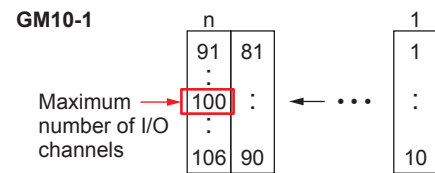

- If you want to use the DI of a GX90XD or GX90WD, only a single module installed in the GM main unit can be used.
- Do not link modules in a way that violates the specifications. Doing so can cause the GM system to crash. For details on the ways modules could be linked to crash the GM system, see the User's Manual.

Limitations depending on the Measurement Mode

Depending on the measurement mode, there are limits to the number of measurement channels, the supported modules, and so on. For the specific limitations, see the limitations provided in the following general specifications.

- GM Data Acquisition System General Specifications (GS 04L55B01-01EN)

Channel Names

Operations such as measurement, computation, and recording are performed on channels.

A channel name is assigned a 4-digit number consisting of a unit number, slot number, and channel number.

- Channel names are specific to the system, so they cannot be changed.
- By setting tags or tag numbers to the channels, you can use any names you like.

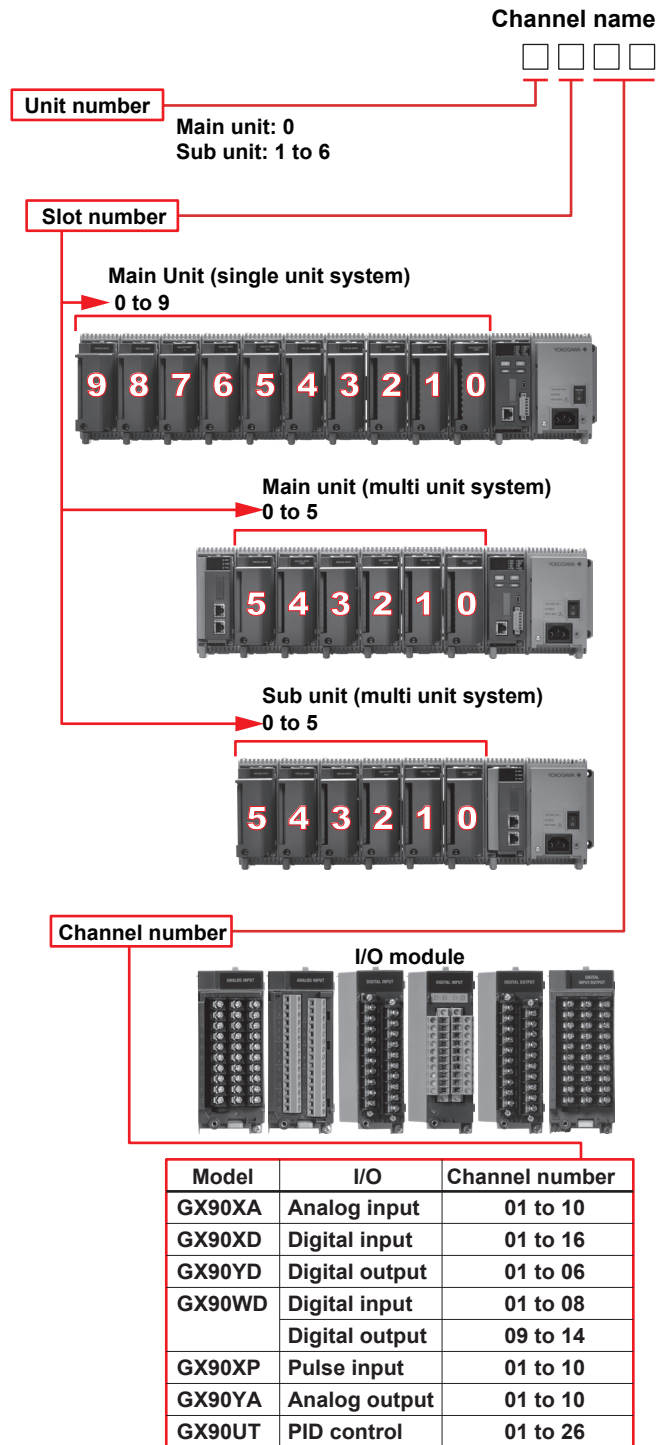

Example: If 10 GX90XAs are linked to the main unit (single unit system), the channel name of channel 3 of slot 5 is "0503."

Blank

Operating Procedure

Product user's manuals can be downloaded from the following URL.

URL: www.smartdacplus.com/manual/ja/

You can download the latest version of the software from the following URL.

URL: www.smartdacplus.com/software/ja/

Download the following software applications.

SMARTDAC+ Standard Hardware Configurator

SMARTDAC+ Standard IP Address Configurator

See the list of electronic manuals on page 4 of IM 04L51B01-91EN, and download them if necessary.

▶ Indicates a reference.

A document number is indicated for manuals other than this manual.

Operations on the GM

Prepare modules.

Check the modules.
Install the module base.
Link the modules.

Configure the system.

▶ “Operating Procedure”
“Installation”

Installation

Connect I/O signals and power.

▶ “Wiring”

Turn on the power.

▶ “Wiring”

Operations on the PC

Configure the GM settings.

▶ “Basic Operations”

If you need to set the time zone or DST (Daylight Saving Time) or both, do so before setting the date and time.

Set the GM10 IP address.
Set the measurement mode
Reconfigure.
Set the date and time.
Set signal inputs.

▶ User's Manual
(IM 04L55B01-01EN)

Configure functions as necessary.

▶ “Basic Operations”

Start recording/measuring.

Checking the Modules

GM10

GM90MB

GM90PS



Power supply connection:
Inlet or M4 screw terminal

I/O modules¹ (without the terminal covers)



GX90EX²



- 1 Some of the modules that can be used with the GM have firmware version conditions. See page 6.
- 2 The GX90EX is used to configure a multi unit system.
The firmware version of the GX90EX that can be used with the GM must be R1.02.01 or later.

System Configuration

GM supports both standalone operation and data acquisition using a PC.

Use a PC to configure the GM settings. To download the dedicated software application, you need to connect to the Internet.

Single Unit System

A system configured with only a main unit.

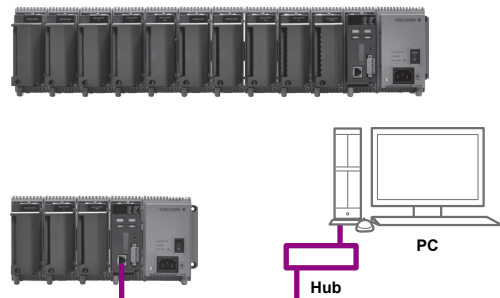

Configuration of settings and real time monitoring are possible using a Web application. A PC with Microsoft Edge or Google Chrome installed is required.

Configuration

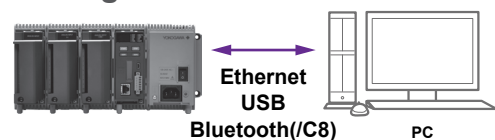

Hardware Configurator is required for USB communication or Bluetooth communication (/C8 option).
A dedicated software application is not required for Ethernet connections.
(IP Address Configurator is used during installation.)

Installing the Module Base

Insert the module from the front of the GM90MB until a click is heard. Then, fasten the screw. (Recommended tightening torque: 0.6 N•m)

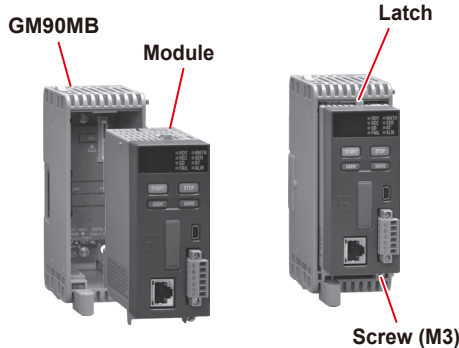

For wall mounting, mount the GM90MB to the wall first, and then install the modules.

Removing a Module

1. Loosen the screw at the bottom section of the module.
2. While pressing down on the latch at the top of the module, pull the module out.

When carrying the unit, be sure that the modules are securely installed.

Linking the Module Base (Module)

1. Check that the slide lock (vertical) is released (see below), align the four protrusions of the GM90MB to the guide, and push it in.

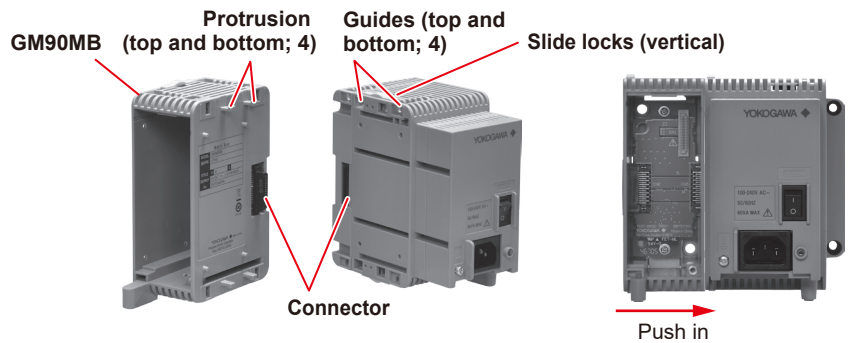

2. After linking the module base, fix in place using the slide lock or the supplied screw. (Recommended tightening torque: 0.4 to 0.5 N•m)

M3 screws for linking (included) (top and bottom; 4) Slide locks (vertical)

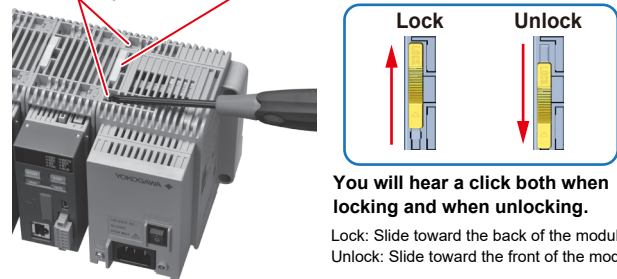

You will hear a click both when locking and when unlocking.

Lock: Slide toward the back of the module.
Unlock: Slide toward the front of the module.

Multi Unit System

A system configured with a main unit connected to sub units. Up to six sub units can be connected to a main unit. Each unit can connect up to six modules.

* There is a limitation on the number of channels based on the GM10 specifications (see IM 04L55B01-01EN).

The multi unit system support only cascaded connections. If connected in a ring, none of the sub units will be identified.

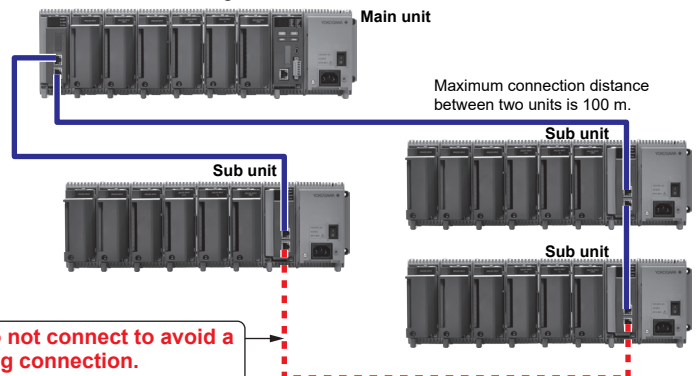
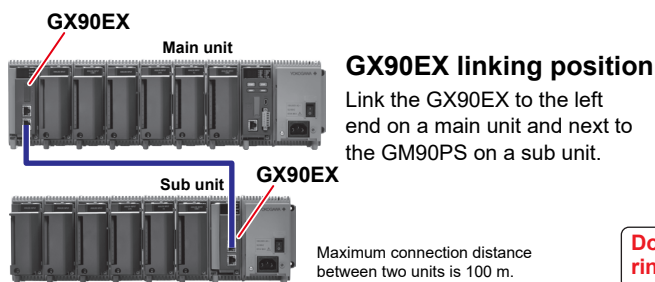

IP Address Configurator Screen Example

- Search for GM10s in the same network segment and list them.
- Set the IP address and other parameters of the GM10.

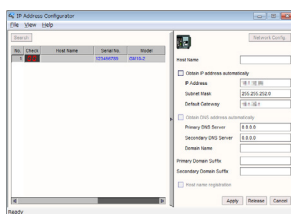

Hardware Configurator Screen Example

- GM settings can be configured offline from a Web browser.

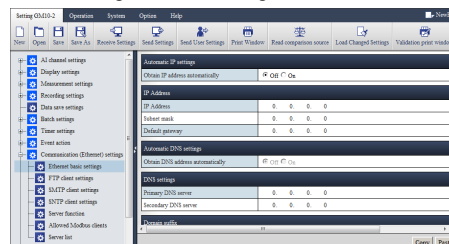

- In the Address box, enter "http://" followed by the GM10 IP address. The Web application starts.

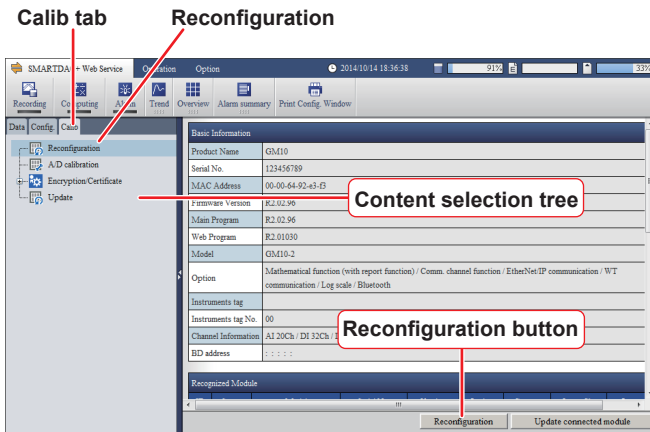

- On the content selection tree, click the **Calib** tab.
- On the tree, click **Reconfiguration**.
- Click **Reconfiguration**.

Setting the Date and Time

If you need to set the time zone or DST (Daylight Saving Time) or both, do so before setting the date and time.

- On the menu bar, click the **Operation** tab.

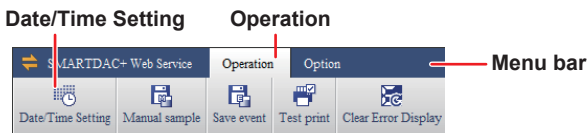

- Click **Date/Time Setting** to display the Date/Time Setting dialog box.
- Set the date and time, and click **Update**.

Configuring a Signal Input

The example here explains how to specify thermocouple type T and 0 to 200°C on channel 1 (0001) of slot (module number) 0.

- On the content selection tree, click the **Config** tab.

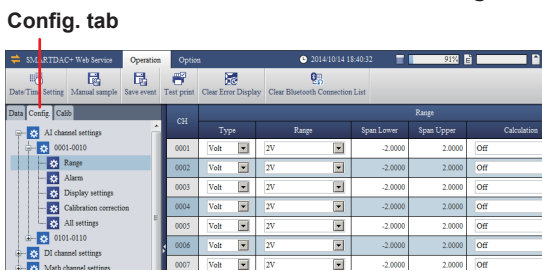

- On the tree, click **AI channel settings, 0001-0010**, and **Range**.
- For channel (CH) 0001, set the following items.
Type: TC, Range: T, Span Lower: 0.0, Span Upper: 200.0
- Click **Update Configuration** in the lower right of the screen.
A Update Configuration dialog box appears.
- Click **OK**.

Setting Measurement and Recording Conditions

The example here explains how to change the recording interval when the following settings are at their default values.

File type: Event, Scan interval: 1s (or 2s),
Recording mode: Free (record data at all times)

- The measurement and recording conditions vary depending on the number of recording channels, recording interval, and so on.
- Click the **Config** tab, **Recording settings**, and **Recording basic settings**.

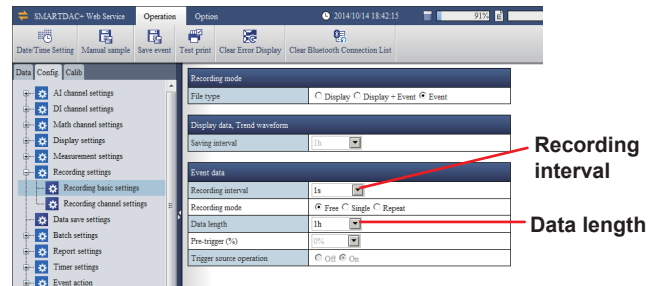

- Select the recording interval.
 - You cannot select a recording interval that is shorter than the scan interval.
 If necessary, set the data length. The data length specifies the size of a single recording data file (the save interval).

- Click **Update Configuration** in the lower right of the screen.

A Update Configuration dialog box appears.

- Click **OK**.

Setting Display Groups

This setting is necessary for displaying measurement data. You can assign channels and the group name to each display group. For details, see the User's Manual. The example here explains how to assign AI channels 0001 to 0010 to group number 1.

- Click the **Config** tab, **Display settings**, **Group settings**, and **1-20**.
- Select the On/Off check box of group number 1, and click the button under Channel set.



The Group number [1] Channel set dialog box appears.

- Set AI channel 001 to 0010 to On, and click **OK**. The selected channels appear under Channel set.
- Click **Update Configuration** in the lower right of the screen.
A Update Configuration dialog box appears.
- Click **OK**.

Configuring the GM via USB Communication

In the case of USB communication, use the Hardware Configurator (hereafter refer to as the software). For details on the features and operating procedures of the software, see the SMARTDAC+ STANDARD Hardware Configurator User's Manual (IM 04L61B01-02EN).

1. Connect a cable to the GM10 USB port (mini B type) to communicate with the PC. Connect using the following communication conditions.
Baud rate: 115200, parity: none, data length: 8 bits, stop bits: 1 bit, handshake: off:off
Make sure that the PC is connected to the Internet. A USB driver will be downloaded automatically.
2. Start the software.

Reconfiguring (Module identification)

1. On the menu bar, click the **Operation** tab and then **Reconfiguration**.
A Communication [Reconfiguration] dialog box appears.
2. Enter the information, and click **OK**.
You can check the port USB number using Windows Device Manager.
3. When a confirmation dialog box appears, click **OK**. A reconfiguration completion dialog box appears.
4. Click **OK**.

Configuring Various Items

For details on settings, see the Web application.

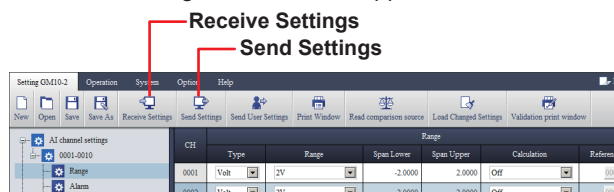

1. On the menu bar, click the **Setting** tab and then **Receive Settings**.
2. When a Communication [Reconfiguration] dialog box appears, click **OK**.
The setup data of the connected GM will appear.
3. Set the items.
4. On the menu bar, click the **Setting** tab and then **Send Settings**.
5. When a Communication [Reconfiguration] dialog box appears, click **OK**.
The setup data will be sent to the connected GM.
You can also save the setup data to be sent later.

Starting to Measure and Record

Starting from the Web Browser

From the Web Application

1. On the menu bar, click the **SMARTDAC+ Web Service** tab and then **Recording**.
2. When a Recording dialog box appears, click **Start recording**. Recording will start.
 - To stop recording, in step 2 above, click **Stop recording**.

From Hardware Configurator

1. On the menu bar, click the **Operation** tab and then **Start Recording**.
2. When a Communication [Reconfiguration] dialog box appears, click **OK**. Recording will start.
 - To stop recording, in step 2 above, click **Stop Recording**.

Starting with the GM10 START Key

Hold down the START key on the GM10 front panel for at least 2 seconds.

Recording will start, and "REC" in the GM10 status display area will light in green.

- Stopping the Recording
Hold down the STOP key for at least 2 seconds. The "REC" indicator will turn off.
- The "REC" LED also turns on and off when recording is started and stopped from the Web application or Hardware Configurator.



To connect to the GM via Bluetooth, "Bluetooth Connection Procedure (/C8 option)" on page 28 of this guide.

Installation

⚠ CAUTION

- Before installing the GM, linking modules, and installing modules, be sure to turn off the power.
- Apply more torque than what is recommended to tighten the screws can deform the case or cause other damage.

Installation Location

This product is designed as open equipment under the CSA/UL/EN/IEC 61010-2-201 standards. In order to comply with these standards, install it as follows:

- Install the GM unit / GX60 in a panel with a door.
- The instrumentation panel or panel used for support must comply with CSA/UL/EN/IEC 61010-2-201 or must be at least IP1X (degrees of protection) and at least IK09.
- Install the GM/GX60 systems in a panel with a door or in a location where can not touch the output terminal block carelessly, when hazardous voltages(over 30VAC or 60VDC) is inputted into output terminal block.

⚠ WARNING

Install the GM / GX60 systems in a panel with a door or in a location where operator or any third person can not operate the power switch carelessly. If the power switch of GM/GX60 systems under operation be turned on or off carelessly, it may result the system down or injury.

⚠ WARNING

On the GX90XA-10-V1, the insulation specification is 1000V DC basic insulation when the common mode voltage exceeds 600 V. When using the system in a common mode voltage environment that exceeds 600 V, install it as follows:

- The GM system and all devices without insulation equivalent to 1000V supplementary insulation connected to the GM system must be installed in a panel with a door.
- Do not access the inside of the panel when the measurement target is turned on.
- The panel used for support must comply with CSA/UL/EN/IEC 61010-2-201 or must be at least IP1X (degrees of protection) and at least IK09.

Install the GM indoors in an environment that meets the following conditions:

- Ambient temperature range between -20 to 60°C (but -20 to 50°C when any of the following.)
When using GM10 (Optional, / C8) and GX90YD, GX90WD, GX90XA-T1 (electromagnetic relay type), GX90YA, GX90UT.

- Ambient humidity between 20 to 85%RH
No condensation should be present.

Note

Condensation may form when moving the GM from a low temperature or humidity environment to a high temperature or humidity environment, or when there is a sudden change in temperature. Temperature or humidity changes may also result in thermocouple measurement errors. In these kinds of circumstances, wait for at least an hour before using the GM, to acclimate it to the surrounding environment.

- Well-Ventilated Location
To prevent overheating, install the GM in a well-ventilated location.
- Minimal Mechanical Vibrations
Install the GM in a location that has minimal mechanical vibrations. Installing the GM in a location that is subject to large levels of mechanical vibration will not only put added stress on its components, it may also impede ordinary measurement.
- Level Location
Install the GM in a level location so that it is not slanted to the left or the right.
- Altitude 2000m or less

Do not install the instrument in the following kinds of places.

- Outdoors
- In Direct Sunlight or Near Heat Sources
Install the GM in a place that is near room temperature (23°C) and that is not subject to large temperature fluctuations. Placing the GM in direct sunlight or near heat sources can cause adverse effects on the internal circuitry.
- Where an excessive amount of soot, steam, moisture, dust, or corrosive gases are present
Soot, steam, moisture, dust, and corrosive gases will adversely affect the GM. Avoid installing the GM in such locations.
- Near Strong Magnetic Field Sources
Do not bring magnets or instruments that produce electromagnetic fields close to the GM. Operating the GM near strong magnetic fields can cause measurement errors.

Installation Procedure

The GM can be installed on a desktop or floor, mounted on a DIN rail, or mounted on a wall. Regardless of the installation method, be sure to install it in an upright orientation.

Unit External Dimensions (Unit: mm)

Depth: 146 mm max.

Main Unit (single unit system)

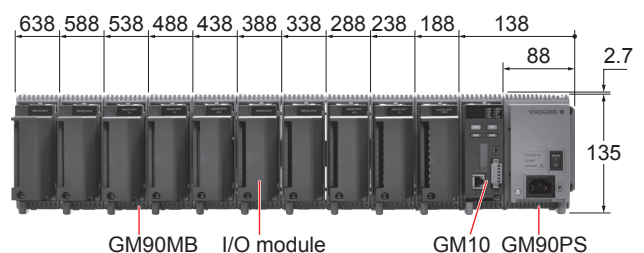

Main Unit (multi unit system)

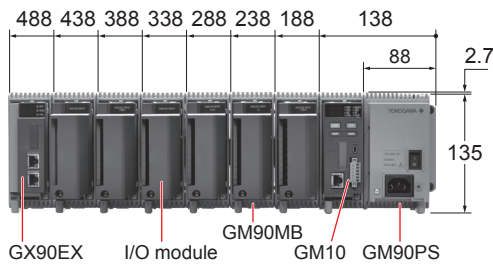

Sub Unit (multi unit system)

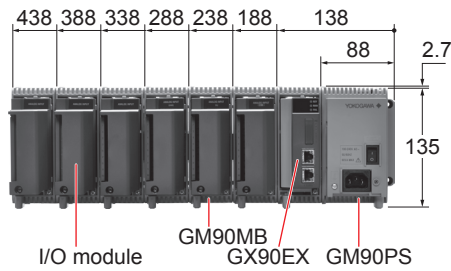

Installing on a Desktop or Floor

The system can be placed upright because the GM90PS and GM90MB have legs. For the module installation procedure, see "Operating Procedure."



Mounting on a DIN Rail

⚠ CAUTION

When mounting on a DIN rail, place screws at 70 mm intervals or less. This is necessary to ensure adequate support.

1. Hook the top section of the DIN rail mounting groove on the rear panel of the GM (GM90PS or GM90MB) to the DIN rail.
2. Push the bottom section of the GM until you hear a click. The GM is fixed in place with the latches on the rear panel of the GM.

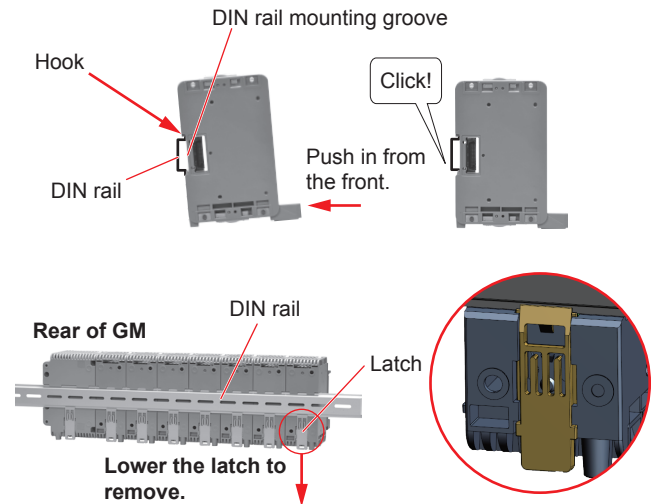

Check that all the latches are securely fastened to the DIN rail.

Removing from the DIN Rail

1. Lower the latch on the rear panel of the GM using a flat-blade screwdriver or the like. Lower it until you hear a click; the latch will be fixed in place at that position.
2. Pull the GM slightly toward you, and lift up to remove.

Vertical Dimensions for DIN Rail Mounting

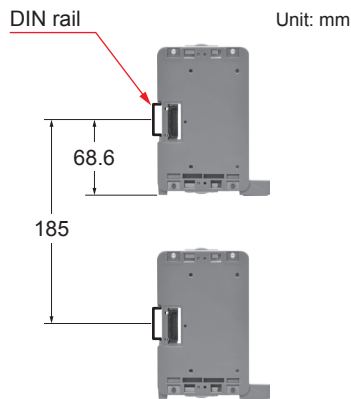

Mounting on a Wall

Wall Mount Dimensions

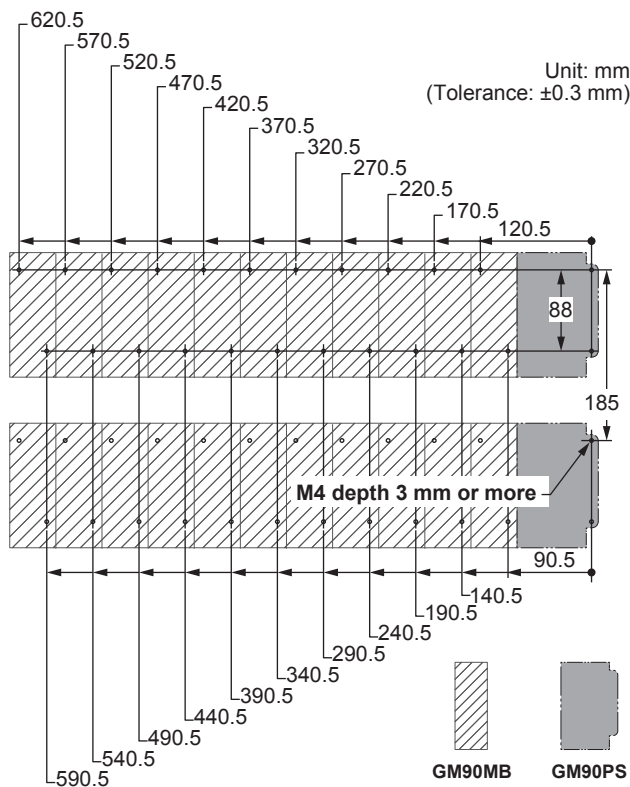

Prepare enough M4 screws (4 mm or longer) (hereafter referred simply as screws) for wall mounting the modules. You need two screws for each module.

Recommended tightening torque: 0.6 to 0.7 N•m

In wall mounting, the GM90PS is the reference.

First, as shown in the figure below, fix the GM90PS securely in place with two screws. Next, link GM90MBs to the GM90PS.



Link GM90MBs to the right of the GM90PS as seen from the front. While pressing the GM90MB against the GM90PS, fasten in place with screws.

- GM90MBs can be fixed in place one at a time or at once after they have been linked.

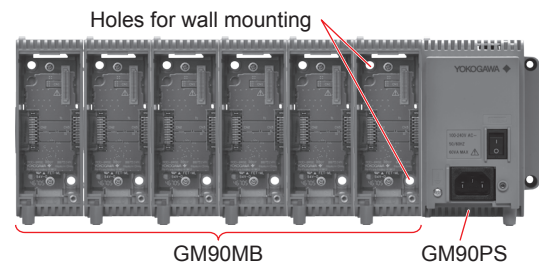

For the linking procedure, see “Operating Procedure” on page 10 of this guide.

After fixing the GM90MBs in place, install the modules.

Note
Install so that nameplate on the right side of the GM90PS is visible.

Wiring

WARNING

- To prevent electric shock while wiring, make sure that the power supply is turned off.
- If a voltage of more than 30V AC or 60V DC is to be applied to the output terminals, use ring-tongue crimp-on lugs with insulation sleeves on all terminals to prevent the signal cables from slipping out when the screws become loose. Furthermore, use double-insulated cables (dielectric strength of 3000V AC or more) for signal cables through which a voltage of 30V AC or 60V DC or more is to be applied to the output terminals. For all other signal cables, use basic insulated cables (dielectric strength of 1500V AC).
To prevent electric shock, attach the terminal cover after wiring and make sure not to touch the terminals.
- For signal cables through which a voltage of 30V AC or 60V DC or more is applied to the input terminals, use double-insulated cables that have sufficient withstand voltage performance for the measurement target and that are suitable for the rating. To prevent electric shock, attach the terminal cover after wiring and make sure not to touch the terminals.
- When the output terminals of the GX90WD are connected to a voltage exceeding 150V AC, the connection is limited to a circuit (secondary power source) derived from the mains circuit (primary power source) of up to 300V AC. Since the insulation specification between output channels is basic insulation, connect so that the potential difference between adjacent channels does not exceed 30V AC or 60V DC. If the potential difference from the adjacent channel exceeds 30V AC or 60V DC, insert an unconnected channel between the two channels.
- Applying a strong tension to the input and output signal cables connected to the GM may damage the cables or the GM terminals. To avoid applying tension directly to the terminals, fix all cables to the mounting panel.
- To prevent fire, use signal cables with a temperature rating of 70°C or more.
- The operating environment of this product is pollution degree 2. Do not allow conductive wiring scraps, chips, or the like to enter inside the product. It cause electric shock, fire, failure, or malfunction. Be careful as facing the GM unit/GX60 up during wiring makes it easy for wiring scraps and chips to enter inside the product.
- Do not apply voltages that exceed the following values to the input terminals. Doing so may damage the instrument.

GX90XA

- Allowable input voltage:
 - ±10V DC for TC/DC voltage (1V range or less)/RTD/DI (Contact), DC mA
 - ±60V DC for DC voltage (2 to 50V range), DI (voltage) input (except High-speed AI)
 - ±120V DC for DC voltage (2 to 100V range) input , DI (voltage) (Highspeed AI)
- Common mode voltage:
 - ±60V DC (under measurement category II conditions)

High-speed AI only
±300V AC rms (under measurement category II conditions)

High withstand voltage only
±600V AC rms / ±600V DC (under measurement category II conditions)
±1000V DC (under measurement category II and basic insulation conditions*)

- * When the module is used under basic insulation conditions, external supplementary insulation is required for safe use. When using the system in a common mode voltage environment that exceeds 600V, install it as follows to add supplementary insulation:
 - To prevent electric shock, install the GM system and all devices connected to the GM system without insulation equivalent to 1000V supplementary insulation in a panel with a door.
 - To prevent electric shock, do not allow cables other than protective ground and main power supply to be directly connected to the outside of the panel.
 - To prevent fire, insert overcurrent protection devices such as fuses between the measurement target and the H and L input terminals of the high voltage input module. For the overcurrent protection device, select a device that supports the common mode voltage to be used. Replacing it regularly is recommended to accommodate degradation due to aging.
 - For other connections, connect to the outside of the panel after adding insulation equivalent to 1000V supplementary insulation to prevent electric shock.
 - To prevent electric shock, make sure that the panel is connected to protective ground. Connect the panel to protective ground according to the local grounding standard.

GX90XD and GX90WD

- Allowable input voltage: +10V DC
- ### GX90XP
- Allowable input voltage: ±10V DC
- ### GX90UT
- Allowable input voltage: ±10V DC for TC/DC voltage (1V range or less)/ RTD/DI (Contact), DC mA ±60V DC for DC voltage (2V range or more), DI (voltage)
 - Common mode voltage: ±60V DC (under easurement category II conditions)

Precautions to Be Taken While Wiring

Take the following precautions when wiring the input signal cables.

- With a screw terminal, we recommend that you use a crimp-on lug with an insulation sleeve (M4 for power supply wiring, M3 for signal wiring).



Crimp-on lug with an insulation sleeve

Recommended signal wiring crimp-on lug N1.25-MS3 (JST Mfg. Co., Ltd.)

- When not using crimp-on lug with an insulation sleeve, use a signal wire with a finished outside diameter of $\varnothing 5$ mm or less.
- With a clamp terminal, we recommend the following wire.
GX90XA
Cross-sectional area 0.05 mm² to 1.5 mm² (AWG30 to 16)
Stripped wire length 5 to 6 mm
GX90XD, GX90XP, GX90YA
Cross-sectional area 0.2 mm² to 1.5 mm² (AWG24 to 16)
Stripped wire length 9 to 10 mm
RS-422/485 (I/C3 option)
Cross-sectional area 0.08 mm² to 1.5 mm² (AWG28 to 16)
Stripped wire length 6 to 7 mm
- When wiring input/output signal cables, observe the minimum bend radius of the cables. For the minimum bend radius, use the specifications indicated by the cable manufacture or six times the cable conductor diameter, whichever is larger.
- Do not allow static electricity to be applied to the terminals.
 - When wiring the terminals, remove static electricity so that static electricity is not applied.
 - If static electricity or similar high-voltage transient noise is applied to the signal line, the system may break.
- Take measures to prevent noise from entering the measurement circuit.
 - Move the measurement circuit away from the power cable (power circuit) and ground circuit.
 - Ideally, the object being measured should not generate noise. However, if this is unavoidable, isolate the measurement circuit from the object. Also, ground the object being measured.
 - Shielded wires should be used to minimize the noise caused by electrostatic induction. Connect the shield to the ground terminal of the GM as necessary (make sure you are not grounding at two points).
 - To minimize noise caused by electromagnetic induction, twist the measurement circuit wires at short, equal intervals.
 - Make sure to earth ground the protective ground terminal through minimum resistance.
- When using internal reference junction compensation on the thermocouple input, take measures to stabilize the temperature at the input terminal.
 - Always use the terminal cover.
 - Do not use thick wires which may cause large heat dissipation (we recommend a cross sectional area of 0.5 mm² or less).
 - Make sure that the ambient temperature remains reasonably stable. Large temperature fluctuations can occur if a nearby fan turns on or off.

- Connecting the input wires in parallel with other devices can cause signal degradation, affecting all connected devices. If you need to make a parallel connection, then
 - Turn the burnout detection function off.
 - Ground the instruments to the same point.
 - Do not turn other instruments on or off during operation. This can have adverse effects on the other instruments.
 - RTD or resistance input cannot be wired in parallel.

Removing and Attaching a Terminal Cover

Removing the Terminal Cover

Loosen the screw at the bottom section of the terminal cover, and remove the cover.

Attaching the Terminal Cover

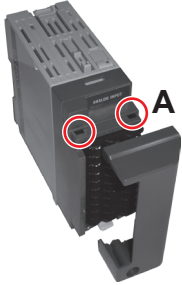

1. Insert the two hooks at the top section on the inside of the terminal cover into A, and push the bottom section of the terminal cover.
2. Fasten the screw at the bottom section of the terminal cover to fix the cover in place.
Recommended tightening torque: 0.6 N•m

The shape of the cover varies depending on the module, but the procedure is the same.

Removing and Attaching a Terminal Block

Removing the GX90XA/GX90WD/GX90UT Terminal Block

Push down on the lever at the bottom section of the module, and pull the terminal block out.

Attaching the GX90XA/GX90WD/GX90UT Terminal Block

Insert the terminal block into the module, and push the lever firmly against the module (at the position indicated by the arrow in the figure).

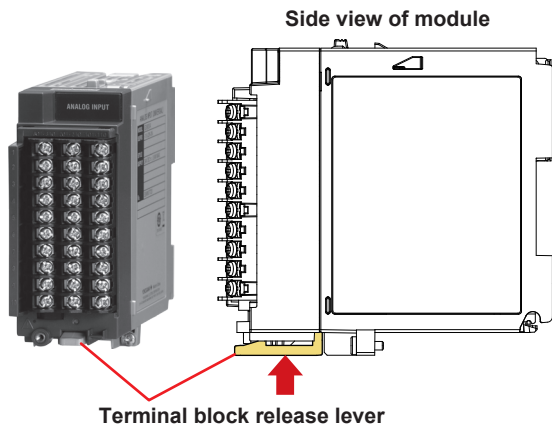

For modules other than the GX90XA, you can use the attachment screw to remove and attach them.

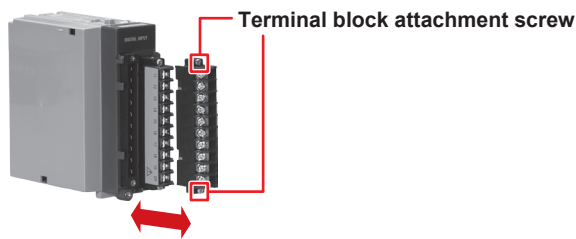

Recommended torque for tightening the terminal block attachment screws: 0.1 N•m

Wiring Procedure

A terminal cover is screwed in place on the I/O terminal block. A label indicating the terminal arrangement is affixed to the cover.

1. Turn off the power, and remove the terminal cover.
2. Connect the signal cables to the terminals.

Recommended torque for tightening the screws	Screw terminal (M3) Clamp terminal	0.5 to 0.6 N•m
	GX90XA:	0.4N•m
	GX90XP:	0.4N•m
	GX90XD:	0.5N•m

3. Replace the terminal cover and fasten it with screws. The recommended tightening torque for the screws is 0.6 N•m.

Note

With a clamp terminal, if you use a single wire whose diameter is 0.3 mm or less, you may not be able to clamp the wire securely to the terminal. Take measures to securely clamp the wire such as by folding the conductor section that will be connected to the clamp terminal in half.

Internal dimensions of the M3 screw terminal (unit: mm)



Wiring the Clamp Terminal

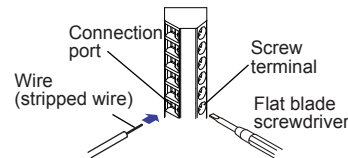

First, loosen the front screw terminal using a flat-blade screwdriver. Insert a wire in the connection port, and tighten the screw terminal.

CAUTION

- When tightening the screw, make sure that the screwdriver remains in line with the screw. Tilting the screwdriver can strip the head or threads of the screw, or cause the screw to insert at an angle.
- Using a precision screwdriver, turn the screw with light downward pressure. Pushing the screw forcefully can damage the terminals.

Wiring to a GX90XA Analog Input Module

Universal / Low withstand voltage relay / Electromagnetic relay / Current (mA) / High withstand voltage type

Terminal Diagram

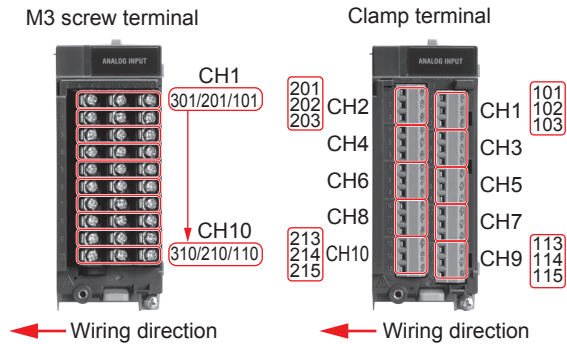

Wiring Diagram

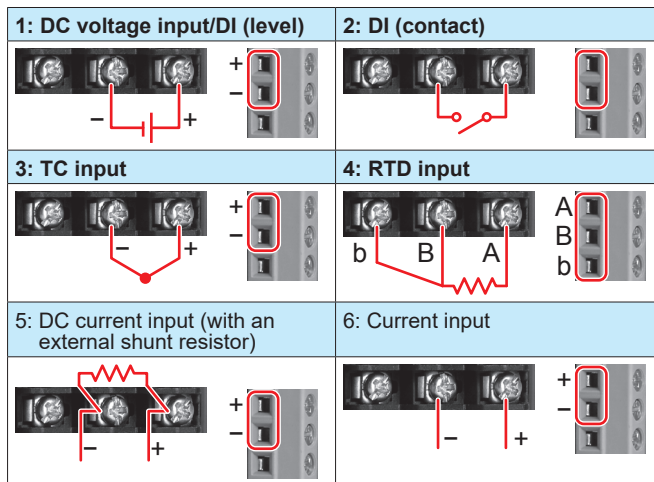

Type	Input type	Wiring
-U2	DC voltage, DI, thermocouple (TC), Resistance temperature detector (RTD), and DC current (by adding an external shunt resistor)	1, 2, 3, 4, 5
-C1	DC current (mA)	6
-L1	DC voltage, thermocouple (TC), DI	1, 2, 3, 5
-T1	(voltage, contact), and DC current (by adding an external shunt resistor)	
-V1		

Terminal Arrangement

M3 screw terminal

CH No.	Term. No.	Symbol	Term. No.	Symbol	Term. No.	Symbol
CH1	301	b ¹	201	-/B	101	+/A
CH2	302	b ¹	202	-/B	102	+/A
CH3	303	b ¹	203	-/B	103	+/A
CH4	304	b ¹	204	-/B	104	+/A
CH5	305	b ¹	205	-/B	105	+/A
CH6	306	b ¹	206	-/B	106	+/A
CH7	307	b ¹	207	-/B	107	+/A
CH8	308	b ¹	208	-/B	108	+/A
CH9	309	b ¹	209	-/B	109	+/A
CH10	310	b ¹	210	-/B	110	+/A

- 1 There are no symbol indications for the electromagnetic relay type, current input type, or low withstand voltage relay type.

Clamp terminal

CH No.	Term. No.	Symbol	CH No.	Term. No.	Symbol
CH2	201	+/A	CH1	101	+/A
	202	-/B		102	-/B
	203	b ¹		103	b ¹
CH4	204	+/A	CH3	104	+/A
	205	-/B		105	-/B
	206	b ¹		106	b ¹
CH6	207	+/A	CH5	107	+/A
	208	-/B		108	-/B
	209	b ¹		109	b ¹
CH8	210	+/A	CH7	110	+/A
	211	-/B		111	-/B
	212	b ¹		112	b ¹
CH10	213	+/A	CH9	113	+/A
	214	-/B		114	-/B
	215	b ¹		115	b ¹

- 1 There are no symbol indications for the electromagnetic relay type, current input type, low withstand voltage type, or high withstand voltage type. The RTD b terminal is connected internally.

High-speed universal

Terminal Diagram

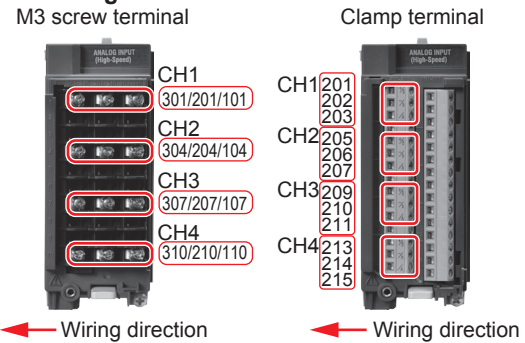

Wiring Diagram

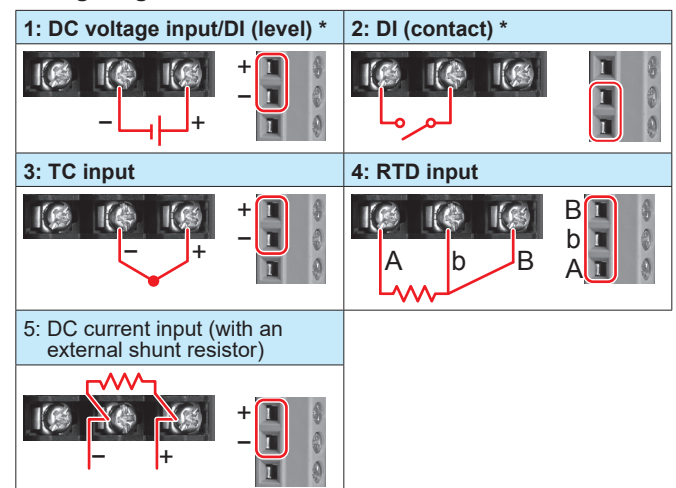

- * Be careful because the DI wiring is different between level and contact.

Terminal Arrangement

M3 screw terminal

CH No.	Term. No.	Symbol	Term. No.	Symbol	Term. No.	Symbol
CH1	301	/A	201	-/b	101	+/B
	302					
	303					
CH2	304	/A	204	-/b	104	+/B
	305					
	306					
CH3	307	/A	207	-/b	107	+/B
	308					
	309					
CH4	310	/A	210	-/b	110	+/B

Clamp terminal

CH No.	Term. No.	Symbol	Term. No.	Symbol
CH1	201	+/B	101	
	202	-/b	102	
	203	/A	103	
	204	Not not use	104	
CH2	205	+/B	105	
	206	-/b	106	
	207	/A	107	
	208	Not not use	108	Not not use
CH3	209	+/B	109	
	210	-/b	110	
	211	/A	111	
	212	Not not use	112	
CH4	213	+/B	113	
	214	-/b	114	
	215	/A	115	

Empty terminals may not be used.

4-wire RTD/resistance

Terminal Diagram

M3 screw terminal

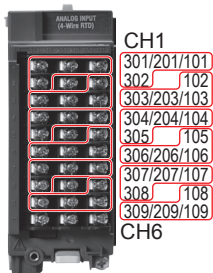

← Wiring direction

Clamp terminal

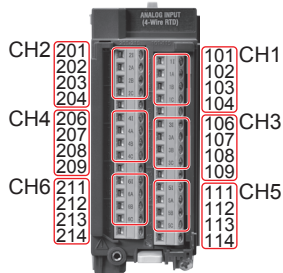

← Wiring direction

Wiring Diagram

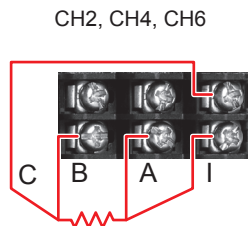
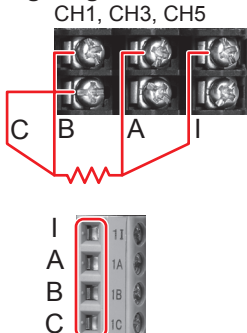

Terminal Arrangement

M3 screw terminal

CH No.	Term. No.	Symbol	Term. No.	Symbol	Term. No.	Symbol
CH1	301	B	201	A	101	I
	302	C	202	Not not use	102	C
	303					
CH2	303	B	203	A	103	I
CH3	304	B	204	A	104	I
	305	C	205	Not not use	105	C
CH4	306	B	206	A	106	I
CH5	307	B	207	A	107	I
	308	C	208	Not not use	108	C
CH6	309	B	209	A	109	I
	310	Not not use	210	Not not use	110	Not not use

Clamp terminal

CH No.	Term. No.	Symbol	CH No.	Term. No.	Symbol
CH2	201	I	CH1	101	I
	202	A		102	A
	203	B		103	B
	204	C		104	C
	205	Not not use		105	Not not use
CH4	206	I	CH3	106	I
	207	A		107	A
	208	B		108	B
	209	C		109	C
	210	Not not use		110	Not not use
CH6	211	I	CH5	111	I
	212	A		112	A
	213	B		113	B
	214	C		114	C

Empty terminals may not be used.

Wiring to a GX90XD Digital Input Module

Terminal Diagram

M3 screw terminal

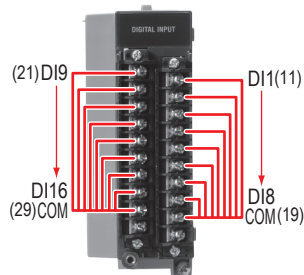

← Wiring direction

Clamp terminal

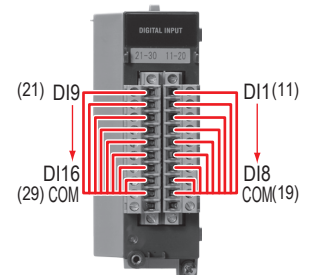

← Wiring direction

Terminal Arrangement

Term. No.	Symbol	Term. No.	Symbol
21	DI9	11	DI1
22	DI10	12	DI2
23	DI11	13	DI3
24	DI12	14	DI4
25	DI13	15	DI5
26	DI14	16	DI6
27	DI15	17	DI7
28	DI16	18	DI8
29	COM	19	COM
30	-	20	-

Internal circuit

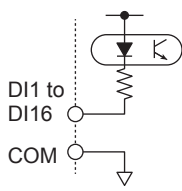

Note: Do not apply voltage outside the allowable input voltage range across input terminals. Doing so may damage the GM.

Input type: Photocoupler isolation
Shared common (COM)
Allowable input voltage range:
0 to 10 V

Wiring to a GX90YD Digital Output Module

Terminal Diagram

M3 screw terminal

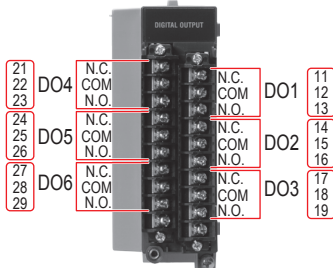

← Wiring direction

Terminal Arrangement

DO No.	Term. No.	Symbol	DO No.	Term. No.	Symbol
DO4	21	NC	DO1	11	NC
	22	COM		12	COM
	23	NO		13	NO
DO5	24	NC	DO2	14	NC
	25	COM		15	COM
	26	NO		16	NO
DO6	27	NC	DO3	17	NC
	28	COM		18	COM
	29	NO		19	NO
	30	-		20	-

Wiring to a GX90WD Digital I/O Module

Terminal Diagram

Terminal Diagram

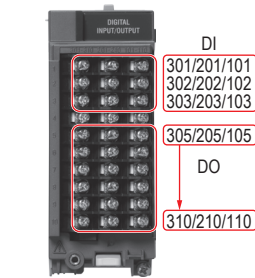

← Wiring direction

Internal circuit

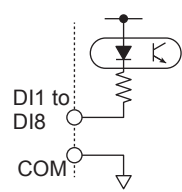

Note: Do not apply voltage outside the allowable input voltage range across input terminals. Doing so may damage the GM.

Input type: Photocoupler isolation
Shared common (COM)
Allowable input voltage range:
0 to 10 V

Terminal Arrangement

CH No.	Term. No.	Symbol	Term. No.	Symbol	Term. No.	Symbol
DI1 to DI8	301	DI3	201	DI2	101	DI1
	302	DI6	202	DI5	102	DI4
	303	DICOM	203	DI8	103	DI7
-	304	-	204	-	104	-
DO1	305	DO1NO	205	DO1COM	105	DO1NC
DO2	306	DO2NO	206	DO2COM	106	DO2NC
DO3	307	DO3NO	207	DO3COM	107	DO3NC
DO4	308	DO4NO	208	DO4COM	108	DO4NC
DO5	309	DO5NO	209	DO5COM	109	DO5NC
DO6	310	DO6NO	210	DO6COM	110	DO6NC

Wiring to a GX90XP Pulse Input Module

Terminal Diagram

M3 screw terminal

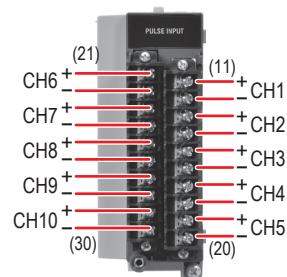

← Wiring direction

Clamp terminal

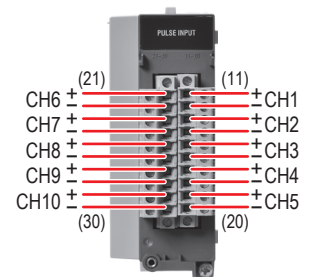

← Wiring direction

Terminal Arrangement

Term. No.	Symbol	Term. No.	Symbol
21	CH6 +	11	CH1 +
22	-	12	-
23	CH7 +	13	CH2 +
24	-	14	-
25	CH8 +	15	CH3 +
26	-	16	-
27	CH9 +	17	CH4 +
28	-	18	-
29	CH10 +	19	CH5 +
30	-	20	-

Internal circuit

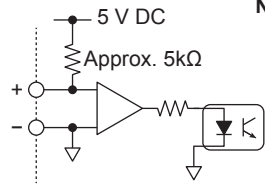

Note: Do not apply voltage outside the allowable input voltage range across input terminals. Doing so may damage the GM.

Input type: Photocoupler isolation
Negative terminal (common) potential shared
Allowable input voltage range: ± 10 V

Wiring to a GX90YA Analog Output Module

Terminal Diagram

M3 screw terminal

Clamp terminal

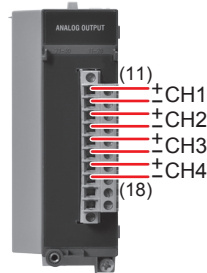
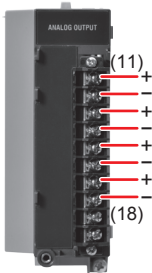

← Wiring direction

← Wiring direction

Terminal Arrangement

CH No.	Term. No.	Symbol
CH1	11	+
	12	-
CH2	13	+
	14	-
CH3	15	+
	16	-
CH4	17	+
	18	-
	19	---
	20	---

Wiring to a GX90UT PID Control Module

Terminal Diagram

M3 screw terminal



301/201/101
302/202/102
303/203/103

304/204/104
305/205/105
306/206/106

307/207/107
308/208/108

209/109
210/110

← Wiring direction

Wiring Diagram

Analog input

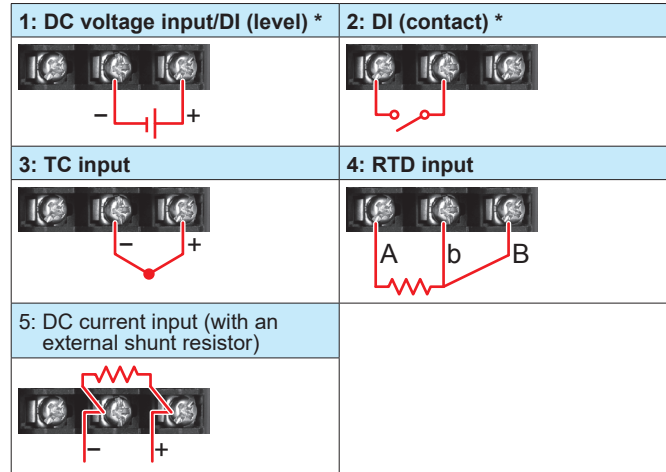

* Be careful because the DI wiring is different between level and contact.

Analog output

DC current output, voltage pulse, 15 V DC loop power supply

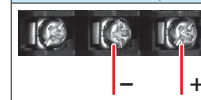

Terminal Arrangement

Term. No.	Symbol	Term. No.	Symbol	Term. No.	Symbol
301	DI3	201	DI2	101	DI1
302	DI6	202	DI5	102	DI4
303	DI-COM	203	DI8	103	DI7
304	DO3	204	DO2	104	DO1
305	DO6	205	DO5	105	DO4
306	DO-COM	206	DO8	106	DO7
307	AI1(/A)	207	AI1(-/b)	107	AI1 (+/B)
308	AI2(/A)	208	AI2(-/b)	108	AI2 (+/B)
309	Do not use	209	AO1 (-)	109	AO1 (+)
310	Do not use	210	AO2 (-)	110	AO2 (+)

Empty terminals may not be used.

Internal circuit

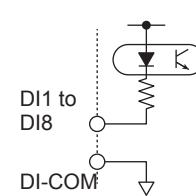

Note: Do not apply voltage outside the allowable input voltage range across input terminals. Doing so can cause a malfunction.

Input type:
Photocoupler isolation
Shared common (DI-COM)
Allowable input voltage range: 0 to 10V

Connecting to the RS-422/485 Connector (/C3 option)

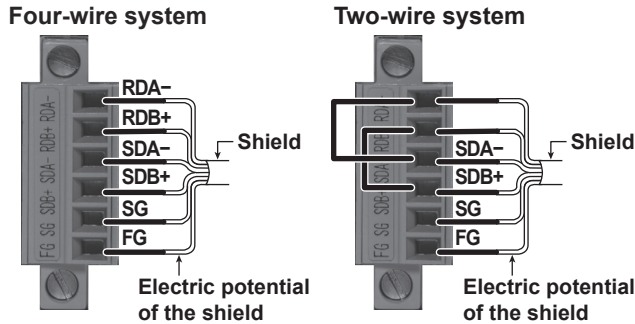

FG (Frame Ground)	Case ground of the GM main unit
SG (Signal Ground)	Signal ground
SDB+ (Send Data B+)	Send data B (+)
SDA- (Send Data A-)	Send data A (-)
RDB+ (Received Data B+)	Receive data B (+)
RDA- (Received Data A-)	Receive data A (-)

Recommended torque for tightening the screws: 0.2 N•m

Connecting to the USB Port

A USB2.0 port (mini B type) is available. Using a dedicated protocol, you can operate and configure the GM10 and output data.



Connecting to the Ethernet Port

Checking the Connection and Communication Status

You can use the indicators that are located above the GM10 Ethernet port to check the connection status of the Ethernet interface.

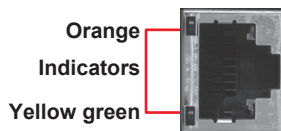

Indicators	Connection Status of the Ethernet Interface
Lit (yellow-green)	The Ethernet link is established.
Off (yellow-green)	The Ethernet link is not established.
Blinking (yellow-green)	Receiving data
Lit (orange)	Connected at 100 Mbps
Off (orange)	Connected at 10 Mbps

Wiring the Power Supply

Use a power supply that meets the following conditions:

Item	Condition Supply voltage suffix code	
	1	2
Rated supply voltage	100 to 240 V AC \pm 10%	12 to 28 V DC
Allowable power supply voltage range	90 to 264 V AC	10 to 32 V DC
Rated power supply frequency	50/60 Hz	-----
Permitted power supply frequency range	50/60 Hz \pm 2%	-----
Power consumption	Supply voltage 100 V AC: 25 VA (normal operation *), 45 VA (maximum)	Supply voltage 12 V DC: 15 VA (normal operation *), 24 VA (maximum)
	Supply voltage 240 V AC: 35 VA (normal operation *), 60 VA (maximum)	Supply voltage 28 V DC: 15 VA (normal operation *), 24 VA (maximum)

* When 10 GX90XA-10-U2 are connected.

Note

- Do not use a supply voltage of 132 to 180 VAC, as this may have adverse effects on the measuring accuracy.
- Notes on the Functional Ground Terminal
 - To reduce noise, use a shielded cable for wiring. Connect the shield to the functional ground terminal or the ground terminal of the GM.
 - Do not wire the protective grounding cord to the functional ground terminal.

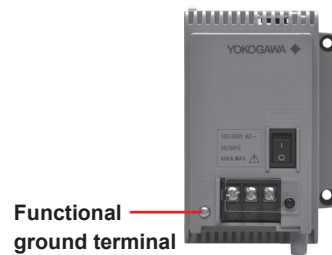

Precautions to Be Taken While Wiring the Power Supply (power supply M4 screw terminals)

Make sure to follow the warnings below when wiring the power supply. Failure to do so may cause electric shock or damage to the instrument.

WARNING

- To prevent electric shock, ensure that the power supply is turned off.
- To prevent fire, use 600 V PVC insulated wires (AWG20 to AWG16; JIS C3307) or wires or cables with equivalent or better performance.
- Make sure to earth ground the protective ground terminal through minimum resistance before you turn on the power.
- Use crimp-on lugs (designed for 4 mm screws) with insulation sleeves to connect both the power cord and the protective ground.
- To prevent electric shock, be sure to close the transparent cover for the power supply wires.

- For safety, provide a double-pole switch in an easily operable location near the GM to disconnect the GM from the main power supply. Put an indication on this switch as the breaker on the power supply line for the GM system and indications of ON and OFF.

Switch specifications

Steady-state current rating	1 A or higher (100 to 240 V AC) 3 A or higher (12 to 28 V DC)
Inrush current rating	60 A or higher (100 to 240 V AC) 70 A or higher (12 to 28 V DC)

Must comply with IEC60947-1 and IEC60947-3.

- Do not add a switch or fuse to the ground line.

Wiring Procedure

1. Turn off the GM90PS power supply, and then remove the transparent power supply terminal cover.
2. Connect the power cord and the protective ground cord to the power supply terminal. Use ring-tongue crimp-on lugs (for M4 screws) with insulation sleeves. The recommended torque for tightening the screws is 1.4 to 1.5 N•m.

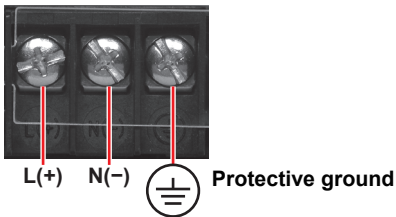

3. Attach the transparent power supply terminal cover, and fasten it with screws.

Precautions to Be Taken When Connecting the Power Supply (Power inlet)

Make sure to follow the warnings below when connecting the power supply. Failure to do so may cause electric shock or damage to the instrument.

WARNING

- Before connecting the power cord, ensure that the source voltage matches the rated supply voltage of the GM90PS and that it is within the maximum rated voltage range of the provided power cord.
- Connect the power cord after checking that the power switch of the GM90PS is turned OFF.
- To prevent electric shock and fire, be sure to use a power cord purchased from Yokogawa Electric Corporation.
- Make sure to connect protective earth grounding to prevent electric shock. Insert the power cord into a grounded three-prong outlet.
- Do not use an extension cord without a protective earth ground. If you do, the instrument will not be grounded.

Connection Procedure

1. Check that the GM90PS power switch is off.
2. Connect the supplied power cord plug to the power inlet.



3. Make that the source voltage is within the maximum rated voltage range of the provided power cord. Then, connect the other end of the cord to the outlet. Use a grounded three-prong outlet.

Precautions to Be Taken While Wiring the Power Supply (Power Supply Suffix Code: 2)

Make sure to follow the warnings below when wiring the power supply. Failure to do so may cause electric shock or damage to the instrument.

WARNING

- Wire the power cable to the power supply terminal, making sure that the polarity is correct.
- Connect the power cables after checking that the power switch of the GM90PS is turned OFF.
- Using other wires may cause abnormal heating or fire.

Wiring Procedure

1. Turn off the GM90PS power supply, and then remove the transparent power supply terminal cover.
2. Wire the power cable to the power supply terminal, making sure that the polarity is correct. Use ring-tongue crimp-on lugs (for M4 screws) with insulation sleeves. The recommended torque for tightening the screws is 1.4 to 1.5 N•m.

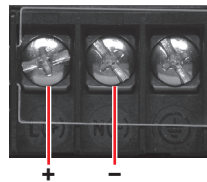

3. Attach the transparent power supply terminal cover, and fasten it with screws.

Turning the Power On and Off

WARNING

If the power switch of GM/GX60 systems under operation be turned on or off carelessly, it may result the system down or injury.

CAUTION

Check the following points before turning on the power switch.

- The power cord or wires are connected properly.
 - The GM is connected to the correct power supply.
- If the input wiring is connected in parallel with another instrument, do not turn on or off the GM or other instrument during operation. If you do, measured values may be affected.

Check the following points before turning off the power switch.

- The GM10 is not accessing the external storage medium.

You can turn the power on and off using the power switch on the front panel of the GM90PS. A self-test takes place for a few seconds, and then the GM will be running.

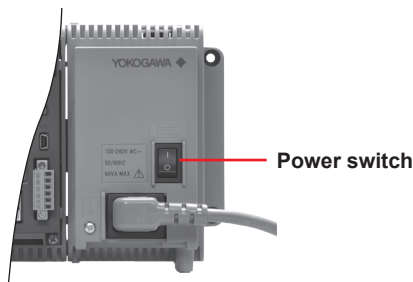

Connecting GX90EX Expansion Modules

The GX90EX is used to configure a multi unit system.

- For the main unit, link the GX90EX to the left end as seen from the front of the unit.
- For a sub unit, link it next to the GM90PS.

Connect the GX90EXs of the main unit and sub units with Ethernet STP (shielded) cables. Only cascaded connection is supported.

Configuring the GX90EX Expansion Modules

Before setting the GX90EX dipswitches, turn off the unit.

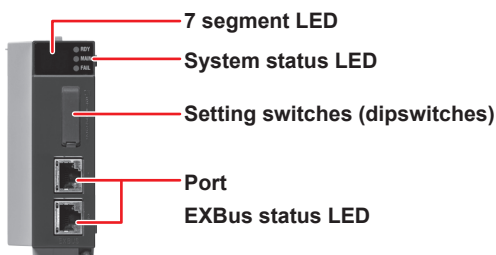

When the GX90EX is connected to the main unit, use master I/O operation. Set dipswitch 8 of the GX90EX to ON (see the figure below).

The unit number is set to 0.

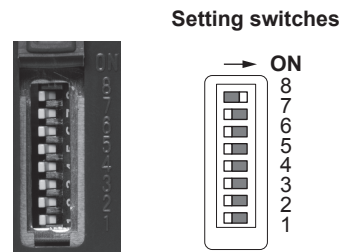

When the GX90EX is connected to a sub unit, set the dipswitches as shown in the following table.

Unit Numbers and Dipswitch Settings

Dipswitch	Unit number						
	0*	1	2	3	4	5	6
4	OFF	OFF	OFF	OFF	OFF	OFF	OFF
3	OFF	OFF	OFF	OFF	ON	ON	ON
2	OFF	OFF	ON	ON	OFF	OFF	ON
1	OFF	ON	OFF	ON	OFF	ON	OFF

* The factory default setting. Unit number 0 is for the main unit.

Fixing the Data Rate to 10 Mbps

To fix the data rate to 10 Mbps, set dipswitch 7 to ON.

Setting switches



7 segment LED

The 7 segment LED displays the unit number and operation errors.

- Unit number indication
Displays the unit number (00 to 06).
- Operation error indication
Displays error codes. Ex (where x is a one digit number or an alphabet letter) will blink.
For the error codes, see "Expansion Module Error Codes" in the User's Manual.

* If an "Fx" indication is displayed, servicing is necessary. Contact your nearest YOKOGAWA dealer for repairs.

System Status Display LED

Three LEDs indicate the operating status of the GX90EX.

Status LED	Color	Description
RDY	Green	Lights during normal operation. Turns off when during a failure.
MAIN	Green	Lights during master I/O expansion operation.
FAIL	Red	Lights during an error.

Setting Switches (Dipswitches)

Use the dipswitches to set the unit number of the expansion module, 10 Mbps fixed mode, and operation mode (master/slave).

Dipswitch Settings

Dipswitch	Description
8	Switches between master I/O expansion and slave I/O expansion modes
7	10Mbps/100Mbps
6	Always OFF (cannot be changed)
5	Always OFF (cannot be changed)
4	
3	
2	For unit numbers
1	

Bluetooth Connection Procedure (IC8 option)

The following procedure applies when you are connecting for the first time when the Bluetooth function is set to On (default value).

1. Check that the GM10 BT LED is not lit.

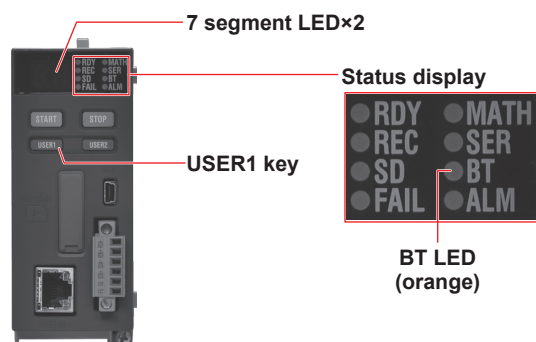

2. Hold down the GM10 USER1 key for at least 3 seconds. The BT LED (orange) will turn on, and the GM will enter the connection standby state.
3. Perform a pairing operation from the PC. A 6-digit authentication code appears on the PC screen and GM10's 7 segment LED. Check that the authentication codes match, and pair the devices. When pairing is complete, a COM port will be assigned. You will need to configure the COM port when connecting.
4. Connect to the GM from the PC. When connecting for the first time, you need to enter the password.
5. Enter **1234** (default value). The BT LED will blink, and a connection will be established with the GM.

Configure the GM using Hardware Configurator. For the configuration procedure, see the SMARTDAC+ STANDARD Hardware Configurator User's Manual (IM 04L61B01-02EN).

Note /// If the Bluetooth function is set to Off, the GM will not enter the connection standby state even if you hold down the USER1 key for more than 3 seconds. ///