

### Introduction

Thank you for purchasing the SMARTDAC+ Series GX20/GP20/GM10 (hereafter referred to as the GX or GP or GM). This manual explains the 920MHz wireless communication function of the GX and GP and GM.

For configuring the 920 MHz wireless communication and descriptions not covered in this manual, see the 920 MHz Wireless Communication User's Manual (IM 04L51B01-41EN), provided as an electronic manual.

For details on the features of the GX/GP/GM/GX70SM and how to use it, read this manual together with the following user's manuals.

- Model GX10/GX20/GP10/GP20 Paperless Recorder First Step Guide (IM 04L51B01-02EN)
- Model GX10/GX20/GP10/GP20 Paperless Recorder User's Manual (IM 04L51B01-01EN)
- Data Acquisition System GM First Step Guide (IM 04L55B01-02EN)
- Data Acquisition System GM User's Manual (IM 04L55B01-01EN)
- Model GX70SM Wireless Input Unit First Step Guide (IM 04L57B01-02EN)
- Model GX70SM Wireless Input Unit User's Manual (IM 04L57B01-01EN)

### Electronic Manuals and General Specifications

You can download these documents from the following web page:

<http://www.smartdacplus.com/manual/en/>

See page 4 in Precaution on the use of SMARTDAC+ (IM 04L51B01-91EN).

### Revisions

November 2017	1st Edition	December 2019	4th Edition
June 2018	2nd Edition	March 2021	5th Edition
March 2019	3rd Edition		

### Notice

NO RIGHTS OR LICENSES, EXPRESS OR IMPLIED, ARE GRANTED TO USE THIRD-PARTY DEVICES IN COMBINATION WITH THESE PRODUCTS IN A WIRELESS MESH NETWORK, OR TO USE THIRDPARTY SERVICES TO ACCESS, MONITOR OR CONTROL THESE PRODUCTS IN A WIRELESS MESH NETWORK VIA THE INTERNET OR ANOTHER EXTERNAL WIDE AREA NETWORK.

### Patent Marking

Covered by one or more claims of patents: <http://sipcollc.com/patent-list/> and <http://intusiq.com/patent-list/>.

### Notes on 920 MHz Wireless Communication

- **The 920 MHz wireless communication (/CM2 and /CS2 options) can only be used in the US.**
  - Only US FCC standards and CSA/UL standards are supported.
- **The 920 MHz wireless communication (/CM3 and /CS3 options) can only be used in the Republic of Korea.**
  - Only KC mark conformity (Radio Waves Act) standards are supported.
- This product has obtained certification. As such, the following acts may be punishable by law.
  - Disassembling or altering the product
  - Removing the certification label
  - Using an antenna other than the specified option
- Communication may not be possible in the following locations due to radio signal reflection.
  - Where strong magnetic field, static electricity, or radio interference occurs

- Rooms with metallic walls (including concrete containing metal reinforcement material), inside cabinets, etc.
- If another wireless device using the same radio frequency band as this product is present in the communication area of this product, data rate degradation or communication errors may occur, preventing normal communication.
- Because this product uses radio signals, bear in mind that communication may be intercepted by third parties.
- This equipment complies with FCC radiation exposure limits set forth for an uncontrolled environment and meets the FCC radio frequency (RF) Exposure Guidelines. This equipment has very low levels of RF energy that is deemed to comply without testing of specific absorption rate(SAR).

### FCC CAUTION

- Changes or modifications not expressly approved by the party responsible for compliance could void the user's authority to operate the equipment.
- This transmitter must not be co-located or operated in conjunction with any other antenna or transmitter.
- This equipment has very low levels of RF energy that is deemed to comply without testing of specific absorption rate(SAR).



### WARNING

#### Using 920 MHz wireless communication

- **Do not install or use inside aircrafts or hospitals or in areas where the use of wireless devices is prohibited.**
- **Do not install or use near automatic doors, fire alarms, and other automatically controlled equipment. The radio signals from this product may affect the equipment and may cause a malfunction.**
- **Do not install or use near cardiac pacemakers or electronic devices that involve highly accurate control or minute signals. Doing so may cause them to malfunction.**
- **Do not use the product in medical equipment or other applications that require high level of safety or in systems (e.g., trunk line communication equipment, computer systems) that require extremely high reliability. Malfunction or failure may cause life-threatening accidents or great social disruption.**



### CAUTION

- **This instrument is an EMC class A product. In a domestic environment this product may cause radio interference in which case the user needs to take adequate measures.**
- **A 급 기기 (업무용 방송통신기자재)**  
이 기기는 업무용(A 급) 전자파적합기기로서 판매자 또는 사용자는 이 점을 주의하시기바라며, 가정외의 지역에서 사용하는 것을 목적으로 합니다.

### QR code

The product may have a QR Code pasted for efficient plant maintenance work and asset information management. It enables confirming the specifications of purchased products and user's manuals. For more details, please refer to the following URL.  
<https://www.yokogawa.com/qr-code>  
QR Code is a registered trademark of DENSO WAVE INCORPORATED.

## MODEL and SUFFIX Codes

### GX20

Model	Suffix Code	Optional Code	Description
GX20			Paperless recorder (Panel mount type, Large display)
Type	-1		Standard (max. no. of measurement ch : 100)
	-2		Large Memory (max. no. of measurement ch : 500)
Language	E		English, degF, DST (summer/winter time)
Optional features	/CM2		920MHz wireless (Master) 1, 3, 4, 9
	/CM3		920MHz wireless (Master) 2, 3, 4, 9

### GP20

Model	Suffix Code	Optional Code	Description
GP20			Paperless recorder (Panel mount type, Large display)
Type	-1		Standard (max. no. of measurement ch : 100)
	-2		Large Memory (max. no. of measurement ch : 500)
Language	E		English, degF, DST (summer/winter time)
Optional features	/CM2		920MHz wireless (Master) 1, 3, 4, 9
	/CM3		920MHz wireless (Master) 2, 3, 4, 9

### GM10

Model	Suffix Code	Optional Code	Description
GM10			Data Acquisition Module for SMARTDAC+ GM
Type	-1		Standard (max. no. of measurement ch: 100)
	-2		Large Memory (max. no. of measurement ch: 500)
Area	E		General
-	0		Always 0
Optional features	/CM2		920MHz wireless (Master) 1, 3, 5, 9
	/CM3		920MHz wireless (Master) 2, 3, 5, 9
	/CS2		920 MHz wireless (Slave) 1, 5
	/CS3		920 MHz wireless (Slave) 2, 5

### GM90PS

Model	Suffix Code	Optional Code	Description
GM90PS			Power Supply Module for SMARTDAC+ GM
Type	-1		Always -1
Area	N		General
Supply voltage	1		100-240V AC
	2		12-28 V DC <sup>6</sup>
Power supply connection	D		Power inlet with UL/CSA cable
	W		Screw terminal (without cable)
-	0		Always 0
Optional features	/W		For 920 MHz wireless 1, 7
	/W3		For 920 MHz wireless 2, 8

- 1 This product can be used only in the USA.
- 2 This product can be used only in the Korea.
- 3 If you specify /CM2 or /CM3, you must also specify the communication channel function (/MC option).
- 4 /CM2, /CM3, /C2 and /C3 cannot be specified together.
- 5 /CM2, /CS2, /CM3, /CS3 and /C3 cannot be specified together.
- 6 Only W (Screw terminal (M4)) is available for the power supply connection.
- 7 Only power supply modules with the /W option can be used with GM10's 920 MHz wireless communication (/CM2 and /CS2 options).
- 8 Only power supply modules with the /W3 option can be used with GM10's 920 MHz wireless communication (/CM3 and /CS3 options).
- 9 If you want to use wireless data retrieval (version 4.09 and later) with the /CM2 or /CM3, a advanced security function (/AS option) must be specified together.

## Optional Accessories (Sold separately)

Name	Part Number/ Model	Minimum Q'ty	Notes
Sleeve antenna (indoor use)	A1061ER	1	For 920MHz wireless
Roof top antenna (indoor and outdoor use, cable length: 2.5 m)	A1062ER	1	For 920MHz wireless

## Names of the GX20/GP20 (/CM2 and /CM3 options) Parts

### Rear panel



- Reboot switch
- USB port for 920 MHz wireless communication configuration
- Status LED
- Antenna connection port

## Names of the GM10 (/CM2, /CS2, /CM3, and /CS3 options) Parts



- Reboot switch
- USB port for 920 MHz wireless communication configuration
- Status LED
- Antenna connection port

## Preparation, Configuration, and Operation Check

To configure (Modbus settings, wireless communication settings) of the GX/GP/GM and check the operation of the GX/GP/GM, follow the procedure below.

### 1 Modbus communication (serial communication) configuration

Configure Modbus communication settings by referring to this manual, GX/GP User's Manual or GM User's Manual, and 920 MHz Wireless Communication User's Manual (IM 04L51B01-41EN).

GX/GP User's Manual: IM 04L51B01-01EN

- Serial communication configuration  
Section 1.22 Configuring the Serial Communication Function (/C2 and /C3 options)
- Communication channels configuration  
Section 1.20 Configuring Communication Channels (/MC option)

GM User's Manual: IM 04L55B01-01EN

- Serial communication configuration  
Section 2.23 Configuring the Serial Communication Function (/C3 option)
- Communication channels configuration  
Section 2.21 Configuring Communication Channels (/MC option)

## 2 Maintenance console preparation

Download the maintenance console from the following URL, and install it.

<http://www.smartdacplus.com/software/smart920/en/>

\* The maintenance console is an application made by Oki Electric Industry Co., Ltd.

## 3 Configuration file preparation

Using the maintenance console, create a configuration file consisting of basic settings, protocols, communication settings, and other wireless network settings according to your wireless network configuration.

You can also use the maintenance console to configure the GX or GP or GM directly without creating a configuration file.

For details on the wireless communication settings, see the 920 MHz Wireless Communication User's Manual (IM 04L51B01-41EN).

## 4 Wireless communication configuration (network configuration)

Connect the GX/GP/GM wireless communication configuration (network configuration) maintenance PC to the GX/GP/GM wireless communication configuration port with a mini USB cable. Then, write the configuration file into the wireless module. After writing, press the reboot switch on the GX/GP/GM or remove the mini USB cable to restart the system and apply the settings. (Hold down the reboot switch for several seconds until the status LED turns off.)

## 5 Network join confirmation

When the GX/GP/GM joins a network,\* the green status ST1 LED blinks slowly, and the green ST2 turns on.

\* Turn the routers (GM10/CS2) on after starting the coordinator (GM10/CM2, GX20/CM2, GP20/CM2, or the like). This will make network connection authentication quicker.

## Connection to the USB Port for 920 MHz Wireless Communication Configuration

A USB2.0 port (mini B type) is available. It is for configuring the 920 MHz wireless communication.



## Status LED Indication (\*1)

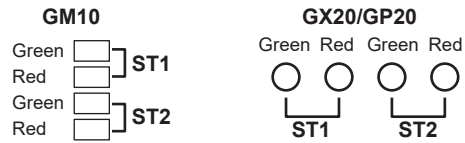

Name	LED display		Status	Notes
	Green	Red		
ST1	Blinking in sync at 1 second intervals		Updating firmware	Transferring files
	On	On	Opening files	
	Blinking at 0.2 second intervals	Off	Normal	Not joined the network
	Blinking at 1 second intervals	Off	Normal	After IP is established upon joining network
	Off	Blinking at 1 second intervals	Failure *2	
	Alternate blinking of green and simultaneous green and red at 1 second intervals		Radio transmission time exceeded	
ST2	On	Off	Network join authentication success/normal	
	Off	Blinking at 1 second intervals	Network join authentication failure*2	
	Blinking in sync at 1 second intervals		No detour route *2	
	Alternate blinking at 1 second intervals		Wireless stopped	
	Blinking	Off	Transmitting/receiving serial communication	
	Off	Off	Not joined the network or disconnected from network	

\*1 The above table does not apply when determining the radio condition using the maintenance console software.

\*2 System error status. Using the maintenance console, correct the installation environment (such as the antenna direction) to an appropriate condition.

## Connecting an Antenna to the GX/GP/GM

### Sleeve antenna

Sleeve antennas (not waterproof) are used indoors or inside a case. Sleeve antennas do not have directivity. They can also be bent and rotated to change the antenna direction. As such, they can be used anywhere indoors.

While turning the antenna to the right, attach the antenna to the antenna connection port.

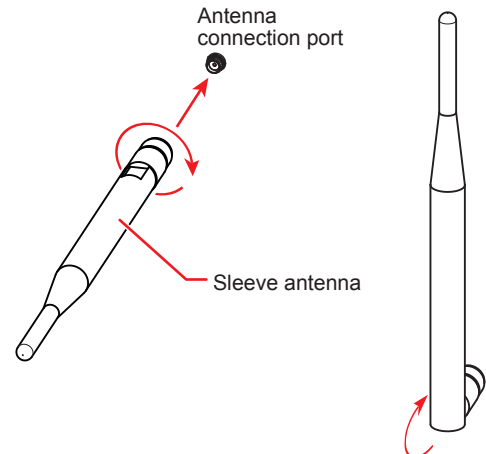

## Roof top antenna

Roof top antennas (waterproof) are used when you want to install only the antenna in a remote location. There is a magnet on the bottom side, so they can be attached to metal boxes and the like. Cable length is 2.5 m.

### Note

- To bring out the full performance of the roof top antenna, install it on top of a metal rectangle board that is at least 10 × 20 cm long.
- Install antennas as far as possible from metal objects and other obstacles. The communication quality may deteriorate if they are close.
- When installing the antenna, make sure no foreign matter gets caught between the bottom side of the antenna and the installation plane.
- Do not bend the antenna cable more than the allowable bend radius of 3 cm.
- When installing the antenna in an area subject to lightning, be sure to install the antenna at a position safe from lightning and at a position lower than the height of other cases.

While turning the antenna connector to the right, attach the antenna to the antenna connection port.

\* Use a torque wrench (wrench width 5/16 inches, tightening torque 0.56 to 0.90 N•m).

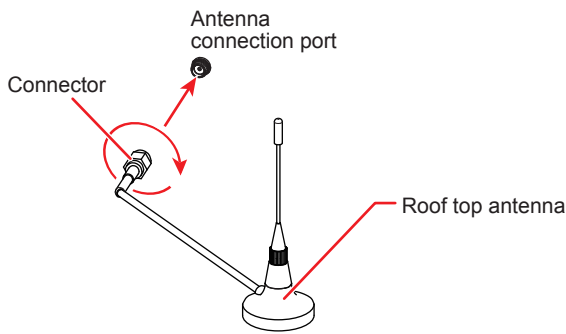

## External Dimensions

Unit: mm (approx. inch)

Unless otherwise specified, tolerance is ±3% (however, tolerance is ±0.3 mm when below 10 mm).

### GX20

When using the sleeve antenna

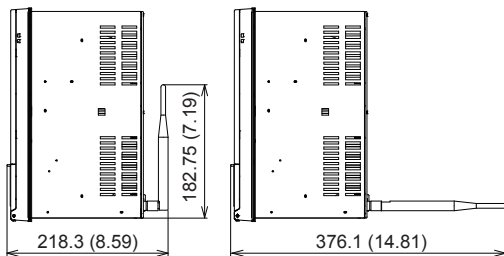

When using the roof top antenna

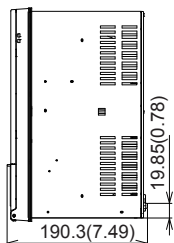

### GP20

When using the sleeve antenna

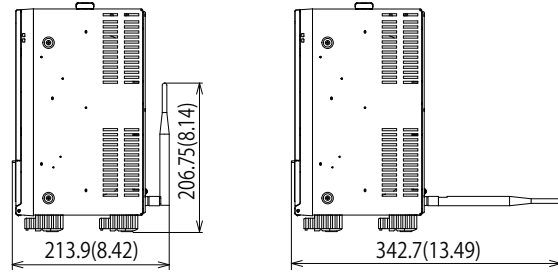

When using the roof top antenna

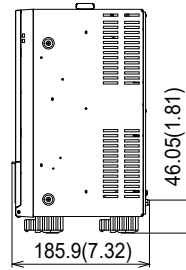

### GM10

When using the sleeve antenna

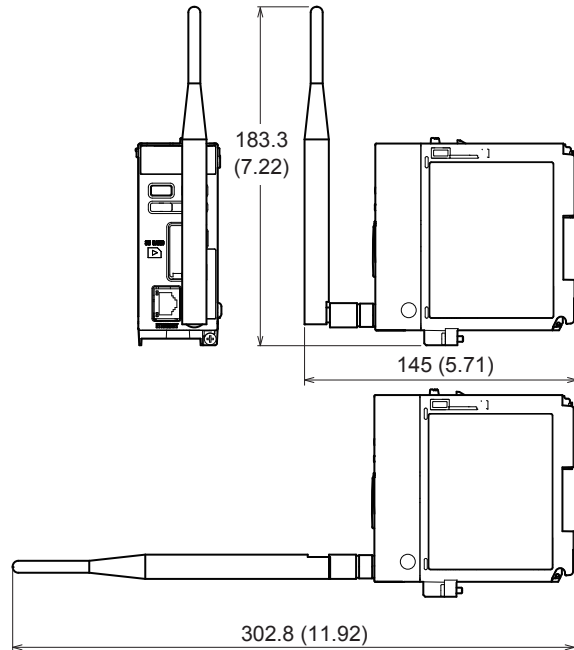

When using the roof top antenna

